

UbiSwitch BaseBoard

SFP+ and PicoClasp Daughterboard for UbiSwitch

MPN: BB-UD1-B-1

Datasheet

March 2025

Board revision B

Contents

Contents	2
1 General Information	3
1.1 Functionality and Features of UbiSwitch BaseBoard	3
1.2 Safety Information	4
1.3 Block Diagram	5
1.4 Included Equipment	8
1.5 RoHS Compliance	8
2 Hardware Interfaces	9
2.1 Board Map	9
2.2 Connectors and Pinouts	10
2.3 Other Interfaces	23
4 Device Configuration	26
5 Mechanical drawing	27
6 Datasheet Changelog	28
7 Contact	28

1 General Information

1.1 Functionality and Features of UbiSwitch BaseBoard

The BotBlox UbiSwitch Baseboard is a breakout system designed to provide a very compact (70mm x 70mm) plug and play system for UbiSwitch. UbiSwitch Baseboard provides 3 x 10Gbps on SFP+ cages and 8 x 1Gbps ethernet ports on Molex PicoClasp headers.

UbiSwitch Baseboard itself does not contain any ethernet switching silicon, rather it contains the necessary connectors and routing required to use UbiSwitch as a complete system. This includes three 10GBASE-R SFP+, and eight Molex PicoClasp headers for direct connection to an external system.

When used with UbiSwitch, UbiSwitch BaseBoard will automatically begin auto negotiation with any connected devices and begin receiving and forwarding frames as an unmanaged ethernet switch.

UbiSwitch BaseBoard runs from a wide input voltage range of 8V to 60V allowing integration into a wide range of applications.

1.1.1 Features

The features described below apply when the board is used with UbiSwitch.

- 3 x 10GBASE-R ethernet ports
- 8 x 10/100/1000BASE-T ethernet ports
- Input voltage range from 8V to 60V
- 69.8mm x 69.8mm board size
- Positive Locking Molex PicoClasp connectors for power and Ethernet ports
- SFP+ connector for 10G capable SFPs
- I2C Mux for access to all I2C busses on SFPs (currently unimplemented in software)

1.1.2 General Information

Voltage Input	8V to 60V DC
Supported Protocols	10BASE-T, 100BASE-TX, 1000BASE-T, 10GBASE-R
Power Consumption	7.2W (idle)
Weight	60 grams
Size	69.8mm x 69.8mm x 18mm (without heatsink)
Operating Temperature	-70°C to +110°C
Storage Temperature	-70°C to +125°C

Table 1: General Information

1.1.3 General Operating Instructions

UbiSwitch Baseboard is designed for use in harsh environments, operating from a nominal supply voltage of 24V, but with the ability to operate from as low as 8V and as high as 60V. UbiSwitch Baseboard is purely a breakout board, and contains no switching capabilities by itself. It must be used with UbiSwitch to create a full ethernet switch system.

To use UbiSwitch Baseboard, first mate the board with UbiSwitch then apply an input voltage from 8 to 60V. Then connect external devices and the Ubi system will begin functioning as an unmanaged switch with up to 3 x 10GBASE-R SFP+ ports and 8 x 1GBASE-T ports.

1.2 Safety Information

- This device can operate on voltages near and above 60V. Please read this manual before operating.
- This device is fully functionally tested prior to shipment however in-application testing prior to integration is recommended.
- This device is provided as an electronic circuit board, and requires integration into chassis for full ingress protection.
- Do not use this product in wet environments without integrating into a chassis.
- Do not operate this product beyond the rated temperature and voltages.

1.3 Block Diagram

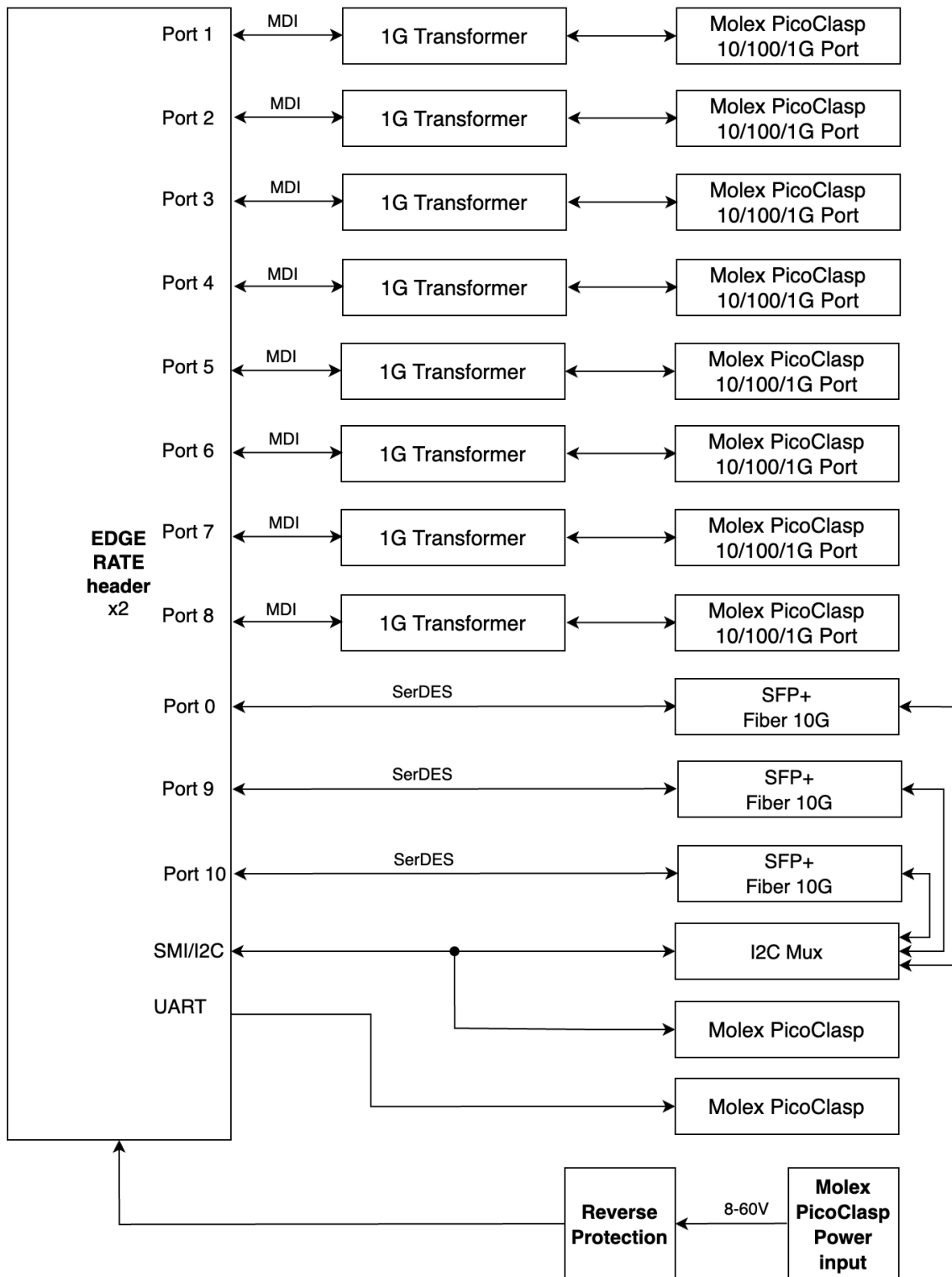

Figure 1: UbiSwitch Baseboard Block Diagram

1.3.1 System Design

To understand how UbiSwitch and UbiSwitch Baseboard work together, it is necessary to understand the UbiSwitch design. While the UbiSwitch has its own datasheet, a brief explanation is provided here.

UbiSwitch contains the main ethernet switch IC. This IC provides eight 1GBASE-T ethernet ports and three 10Gbps 10GBASE-R ports. These eleven ports are routed directly to a Samtec Edge Rate connector on UbiSwitch, along with a number of other power and control lines.

Figures 2 and 3 below show the signals carried on the UbiSwitch board.

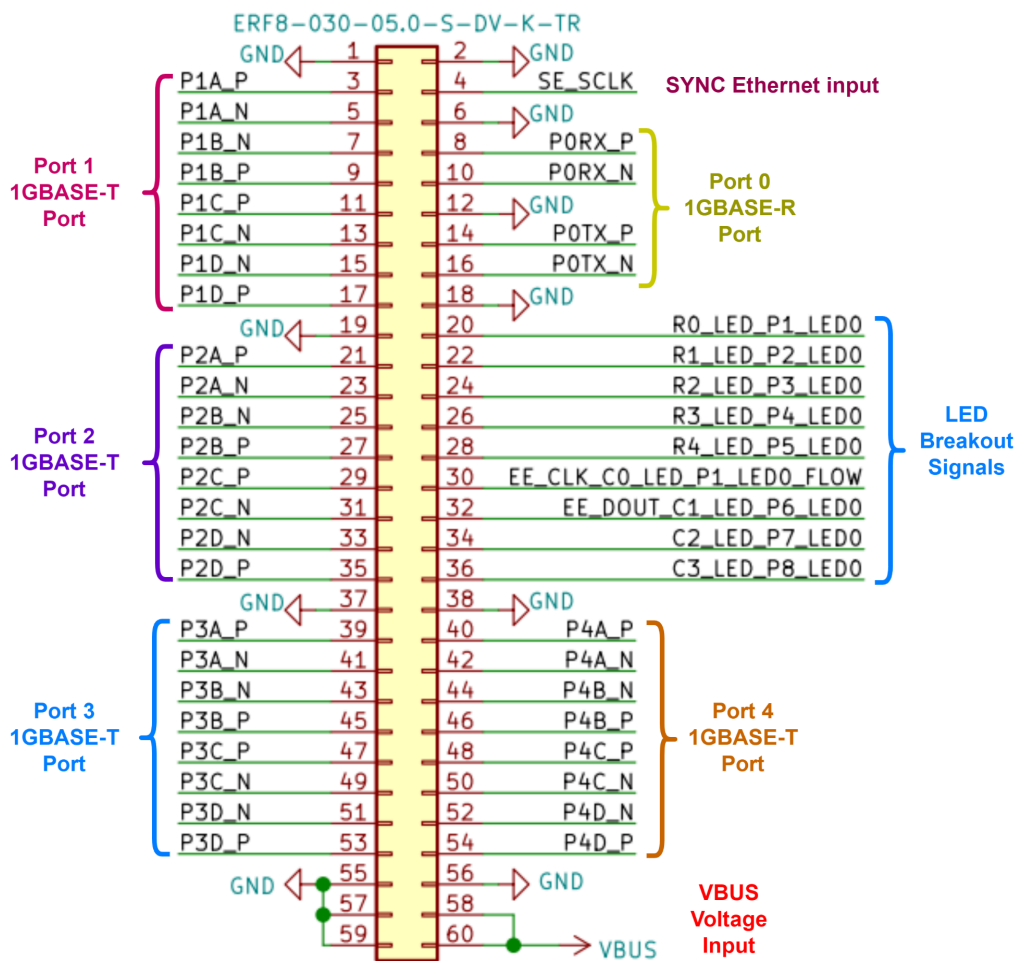

Figure 2: Signals on the UbiSwitch carried on the Samtec Edge Rate header 1

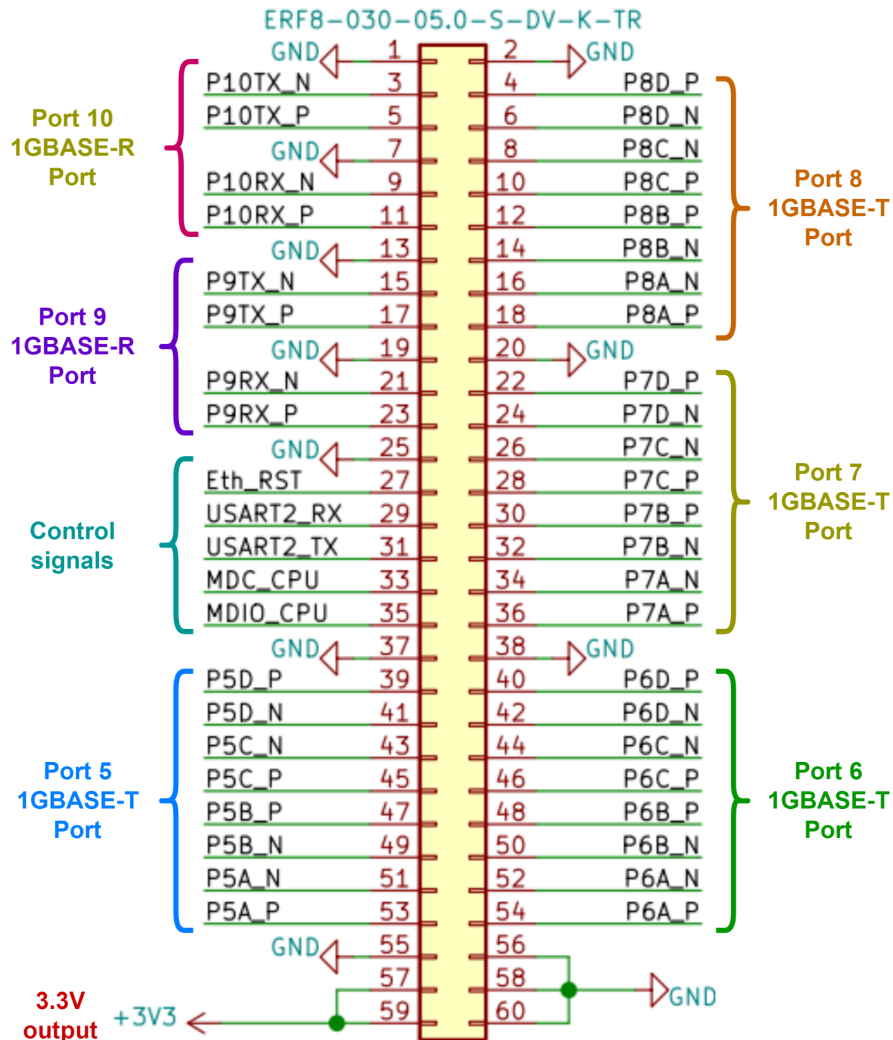

Figure 3: Signals on the UbiSwitch carried on the Samtec Edge Rate header 2

The signals shown in Figure 2 and Figure 3 enter UbiSwitch Baseboard through its corresponding Samtec EdgeRate header. UbiSwitch Baseboard then routes these signals in the following ways.

- Ports 1-8 (the 10/100/1GBASE-T ports) are routed to Molex PicoClasp headers through ethernet magnetics.
- Ports 0, 9 and 10 (the 10GBASE-R ports) are routed to 1x3 SFP+ connector.
- UbiSwitch Baseboard houses a Molex PicoClasp header for 8-60V power input (VBus). This is then routed to the Samtec Edge Rate header to power the UbiSwitch.
- Serial signals are routed to a Molex PicoClasp header.
- SMI signals are routed to a Molex PicoClasp header, and also to an I2C mux that connects to the I2C busses on all three SFP ports.

- LED signals are routed to a Molex PicoClasp header.

In this way UbiSwitch Baseboard provides physical access to the 1GBASE-T ports and 10GBASE-R from UbiSwitch. It also will provide access to the SFP I2C management busses for SFP configuration.

As of May 2024, the SFP I2C management feature is currently not implemented. Get in touch for the latest status of this feature.

1.3.2 Auto negotiation

All ports on the UbiSwitch system support auto negotiation, auto-MDI/MDIX and polarity correction. Each port will auto negotiate with the connected device to achieve the fastest possible speed. The fastest possible speed will depend on what the connected device is capable of, and the quality of the cabling between UbiSwitch Baseboard and the connected device. This simplifies system connectivity, meaning eight of the ports on UbiSwitch Baseboard are compatible with any 10/100/1G device and three ports are compatible with Fiber SFP+ devices. For more information on this, see section 2.4 on the UbiSwitch datasheet.

1.4 Included Equipment

The product includes the following:

- 1 x UbiSwitch BaseBoard
- 8 x Molex PicoClasp to RJ-45, 8 way, 400mm (UL1061, 28AWG Stranded) (BB-PCRJ1-8-0.4) (Data Cable) (UTP CAT5e Equivalent)
- 2 x Molex PicoClasp to Tinned Leads, 4 way, 400mm (UL1061, 28AWG Stranded) (BB-PCTL1-4-0.4) (Power Cable)
- 1 x Molex PicoClasp to Tinned Leads, 9 way, 400mm (UL1061, 28 AWG Stranded) (BB-PCTL1-9-0.4) (LED Cable)

1.5 RoHS Compliance

The BotBlox UbiSwitch Baseboard complies with the RoHS (Restriction of Hazardous Substances Directive) Certificate of Compliance.

2 Hardware Interfaces

2.1 Board Map

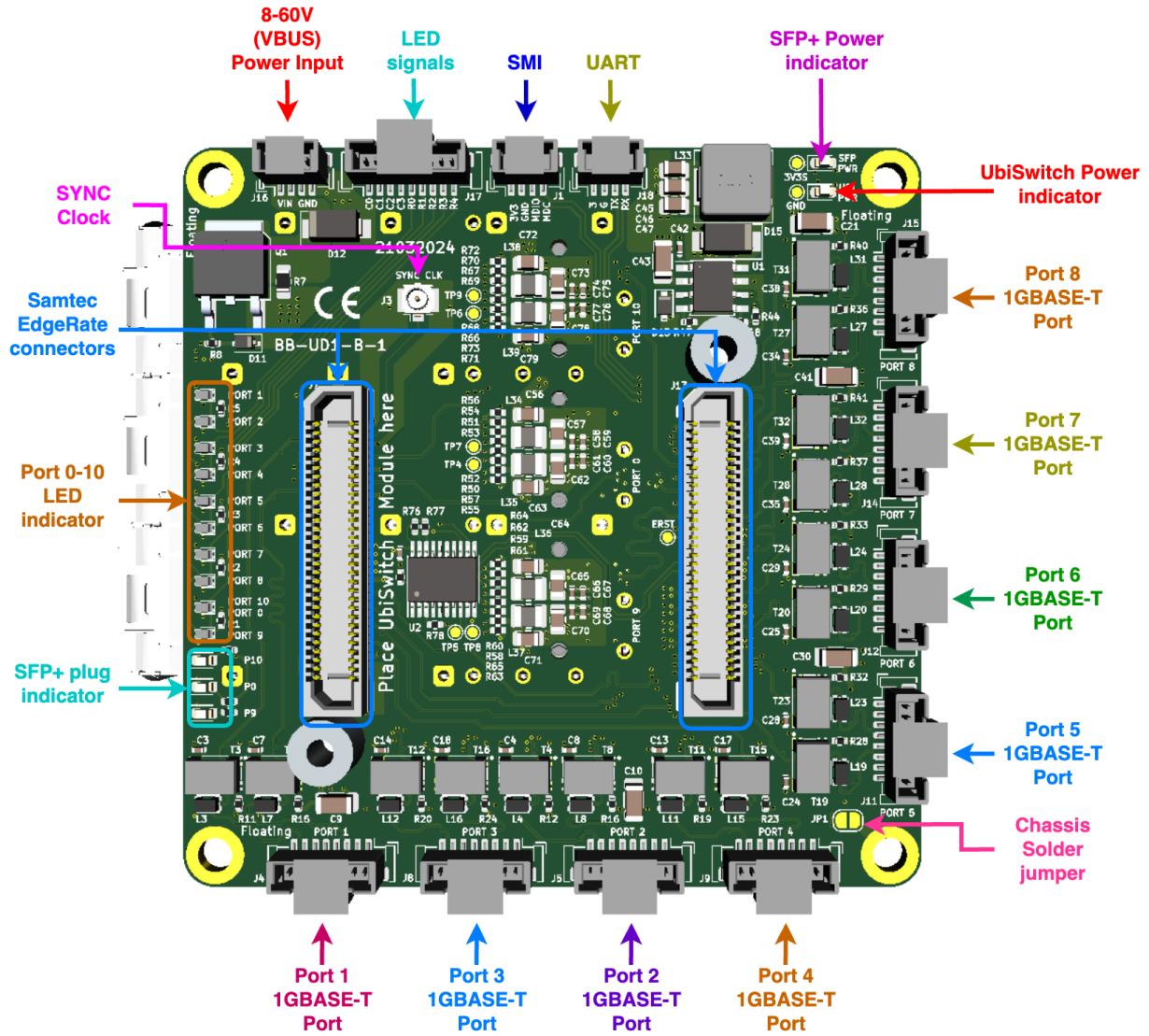

Figure 4: UbiSwitch Baseboard Board Map (front)

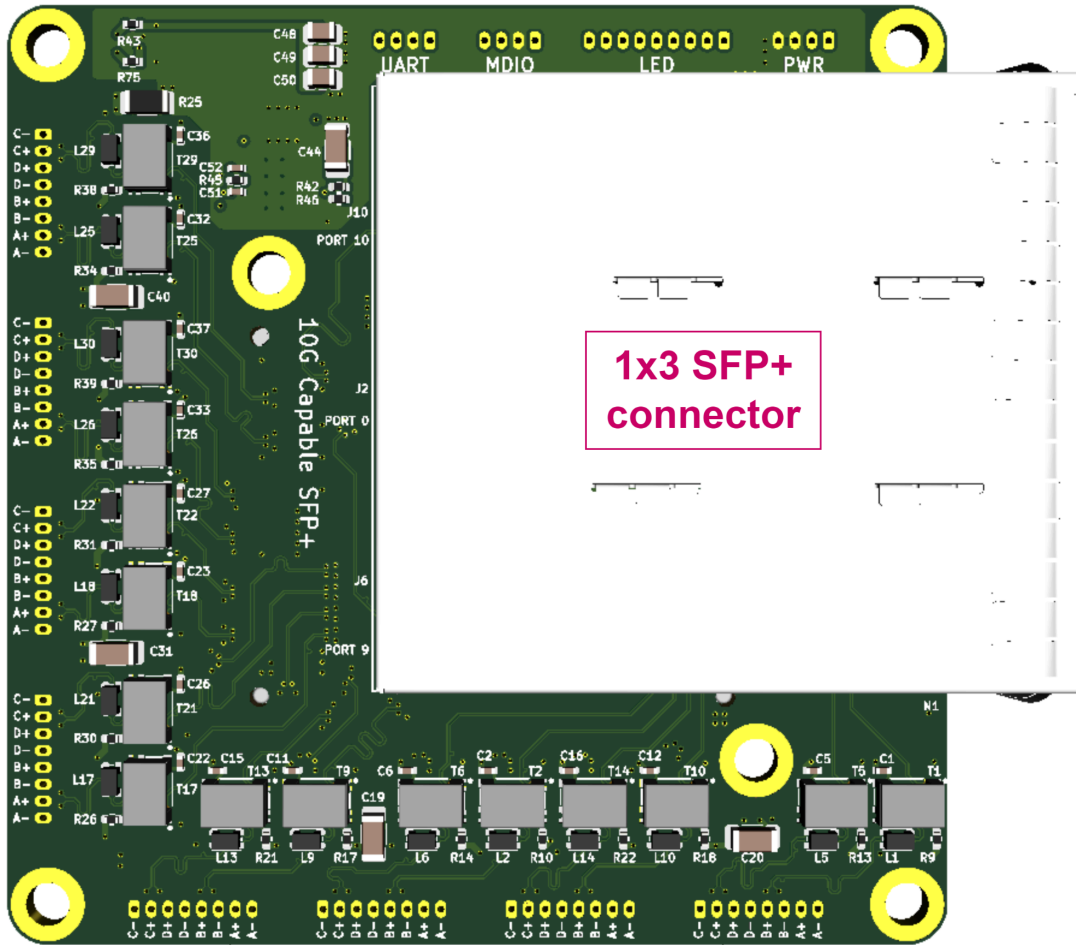

Figure 5: UbiSwitch Baseboard Board Map (back)

2.2 Connectors and Pinouts

2.2.1 Edge Rate connector

The 8 ports, 3 SerDES, SMI, LED signals, UART, input voltage and output voltage are placed onto a Samtec Edge Rate™ (MPN: [ERF8-030-05.0-S-DV-K-TR](#)) stackable header. The Edge Rate connector on the UbiSwitch Baseboard Board is shown in figure 6 below.

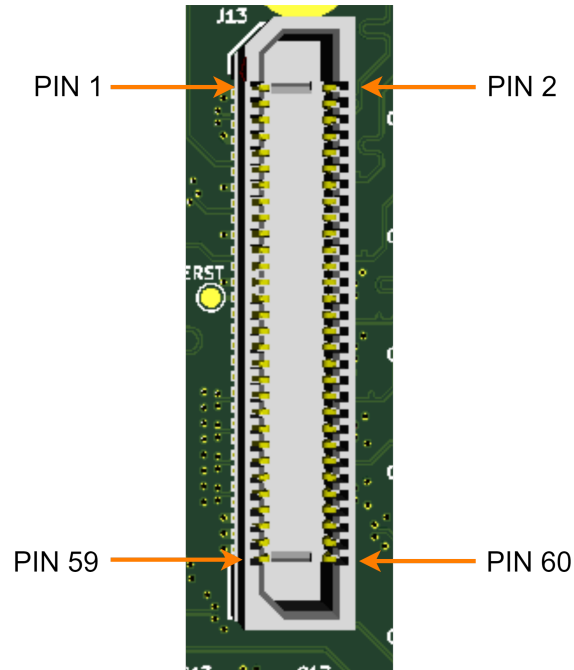

Figure 6: Edge Rate connector on UbiSwitch Baseboard

Mating part: [ERM8-030-02.0-S-DV-TR](#) (used on UbiSwitch)

The mating method is shown in figure 7 below.

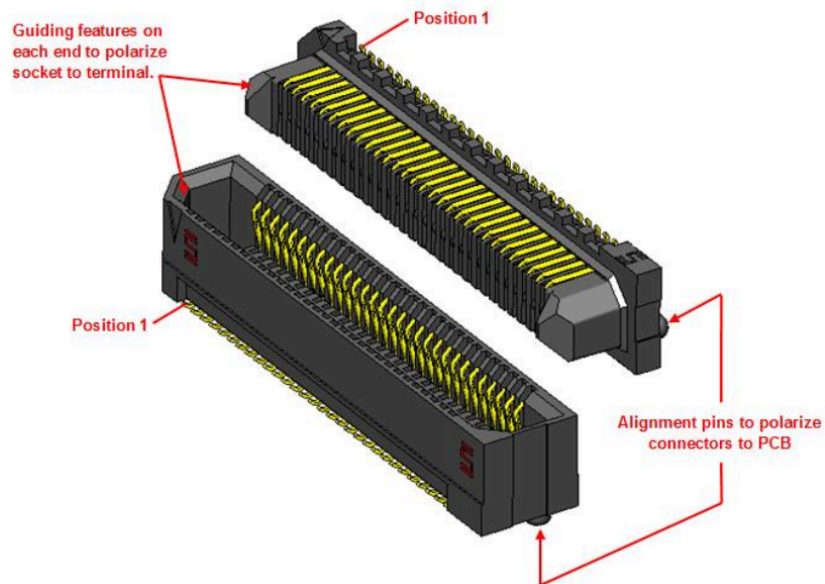

Figure 7: Edge Rate connector mating

The signal to pin assignments used on UbiSwitch Baseboard is detailed in table 3 and table 4 below.

Connector	Pin name	Pin number	Description
J7	GND	1	Ground
	GND	2	Ground
	GND	6	Ground
	GND	12	Ground
	GND	18	Ground
	GND	19	Ground
	GND	37	Ground
	GND	38	Ground
	GND	55	Ground
	GND	56	Ground
	GND	57	Ground
	GND	59	Ground
	VBUS	58	Input supply voltage, 8V to 60V
	VBUS	60	Input supply voltage, 8V to 60V
	P1A_P	3	Port 1 1000BASE-T Differential Data Pair A ~ D Note: 100BASE-TX and 10BASE-Te are also supported on the A and B pairs.
	P1A_N	5	
	P1B_P	9	
	P1B_N	7	
	P1C_P	11	
	P1C_N	13	
P1D_P	17		
P1D_N	15		

P2A_P	21	Port 2 1000BASE-T Differential Data Pair A ~ D Note: 100BASE-TX and 10BASE-Te are also supported on the A and B pairs.
P2A_N	23	
P2B_P	27	
P2B_N	25	
P2C_P	29	
P2C_N	31	
P2D_P	35	
P2D_N	33	
P3A_P	39	Port 3 1000BASE-T Differential Data Pair A ~ D Note: 100BASE-TX and 10BASE-Te are also supported on the A and B pairs.
P3A_N	41	
P3B_P	45	
P3B_N	43	
P3C_P	47	
P3C_N	49	
P3D_P	53	
P3D_N	51	
P4A_P	40	Port 4 1000BASE-T Differential Data Pair A ~ D Note: 100BASE-TX and 10BASE-Te are also supported on the A and B pairs.
P4A_N	42	
P4B_P	46	
P4B_N	44	
P4C_P	48	
P4C_N	50	
P4D_P	54	
P4D_N	52	
P0TX_P	14	SerDES Port 0 Transmit Data bus positive
P0TX_N	16	SerDES Port 0 Transmit Data bus negative

	P0RX_P	8	SerDES Port 0 Receive Data bus positive
	P0RX_N	10	SerDES Port 0 Receive Data bus negative
	R0_LED	20	Parallel multiplexed LED outputs. These active low LED pins directly drive the port's LEDs supporting a range from 1 to 20 LEDs in a multiplexed fashion. In this mode the cathode of each LED connects to these pins through a series current limiting resistor. The anode of each LED connects to one of the Cx_LED pins below
	R1_LED	22	
	R2_LED	24	
	R3_LED	26	
	R4_LED	28	
	C0_LED	30	
	C1_LED	32	connect to the anode of LED column 1 for each row
	C2_LED	34	connect to the anode of LED column 2 for each row
	C3_LED	36	connect to the anode of LED column 3 for each row
	SE_SCLK	2	Synchronous Ethernet Source Clock. This is a 25 MHz reference clock which can be used as a synchronous clock input from the board or system. This signal must come from a high quality clock conditioning circuit or Synchronous Ethernet PLL.

Table 2: UbiSwitch Baseboard J7 connector pin assignments

Connector	Pin name	Pin number	Description
J13	GND	1	Ground
	GND	2	Ground
	GND	7	Ground
	GND	13	Ground
	GND	19	Ground
	GND	20	Ground
	GND	25	Ground
	GND	37	Ground

	GND	38	Ground
	GND	55	Ground
	GND	56	Ground
	GND	58	Ground
	GND	60	Ground
	+3V3	57	Output 3.3V, maximum 0.5A
	+3V3	59	Output 3.3V, maximum 0.5A
	P5A_P	53	Port 5 1000BASE-T Differential Data Pair A ~ D Note: 100BASE-TX and 10BASE-Te are also supported on the A and B pairs.
	P5A_N	51	
	P5B_P	47	
	P5B_N	49	
	P5C_P	45	
	P5C_N	43	
	P5D_P	39	
	P5D_N	41	
	P6A_P	54	Port 6 1000BASE-T Differential Data Pair A ~ D Note: 100BASE-TX and 10BASE-Te are also supported on the A and B pairs.
	P6A_N	52	
	P6B_P	48	
	P6B_N	50	
	P6C_P	46	
	P6C_N	44	
	P6D_P	40	
	P6D_N	42	
	P7A_P	36	Port 7 1000BASE-T Differential Data Pair A ~ D Note: 100BASE-TX and 10BASE-Te are also supported on the A and B pairs.
	P7A_N	34	
	P7B_P	30	

	P7B_N	32		
	P7C_P	28		
	P7C_N	26		
	P7D_P	22		
	P7D_N	24		
	P8A_P	18	Port 8 1000BASE-T Differential Data Pair A ~ D Note: 100BASE-TX and 10BASE-Te are also supported on the A and B pairs.	
	P8A_N	16		
	P8B_P	12		
	P8B_N	14		
	P8C_P	10		
	P8C_N	8		
	P8D_P	4		
	P8D_N	6		
	P9TX_P	17		SerDES Port 9 Transmit Data bus positive
	P9TX_N	15		SerDES Port 9 Transmit Data bus negative
	P9RX_P	23	SerDES Port 9 Receive Data bus positive	
	P9RX_N	21	SerDES Port 9 Receive Data bus negative	
	P10TX_P	5	SerDES Port 10 Transmit Data bus positive	
	P10TX_N	3	SerDES Port 10 Transmit Data bus negative	
	P10RX_P	11	SerDES Port 10 Receive Data bus positive	
	P10RX_N	9	SerDES Port 10 Receive Data bus negative	
	ETH_RST	27	Active low system reset	
	MDC_CPU	33	Management Data Clock, Slave. MDC_CPU is the reference clock input for the serial management interface (SMI) that connects to an external SMI master, typically a CPU. A continuous clock stream is not expected. The maximum frequency supported is 20.0 MHz The CPU's SMI interface is used to access the device's registers but it cannot be used	

			until the device's INTn pin becomes active low.
	MDIO_CPU	35	Management Data I/O, Slave. MDIO_CPU is used to transfer management data in and out of the device synchronously to MDC_CPU
	USART2_RX	29	Microcontroller USART RX line
	USART2_TX	31	Microcontroller USART TX line

Table 3: UbiSwitch Baseboard J13 connector pin assignments

2.2.2 SFP+ connector

UbiSwitch Baseboard supports 3x10Gbps Fiber SFP+ module. To achieve a very small form factor, a 1x3 SFP+ cage is used.

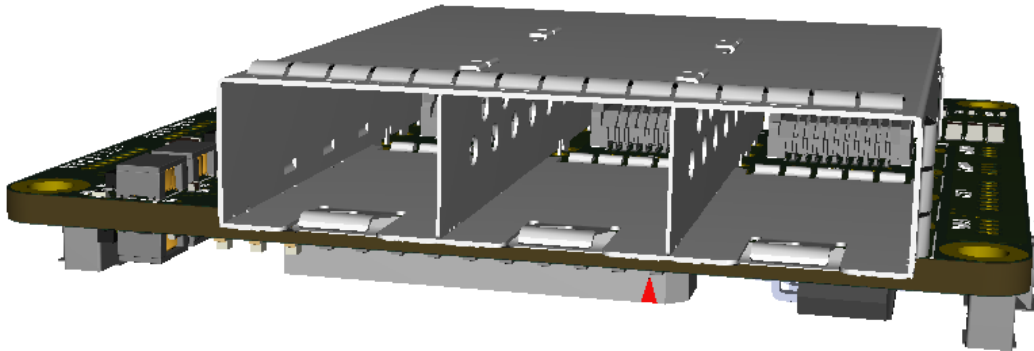

Figure 8: 1x3 SFP+ connector on UbiSwitch Baseboard

Out the box, only 10G capable SFPs can be used with the UbiSwitch module, meaning these SFP ports on UbiSwitch BaseBoard are only compatible with 10G capable SFPs. This is because these three ports are, by default, configured with a 10GBASE-R interface. This means you should use a 10G SFP, such as the [Cisco SFP-10G-T-X module](#).

This is not a hard restriction however. Ports 9 and 10 SFPs can be configured to run in 1000BASE-X mode for 1G SFPs either by making a small solder connection on UbiSwitch Module (described [here](#)). All three SFPs (ports 0, 9 and 10) will be able to be configured via the UbiSwitch running BloxOsLite in the future.

Please note that these cages can occasionally be quite stiff on initial insertion of an SFP. This is usually only the case on the first or second insertions, and the cages will become more compliant over time. This means you may need to apply a fair amount of force upon first insertion. To apply this force without damaging the delicate transformers on the board, see figure 9 below. A video demonstration can be found at the link below.

https://www.youtube.com/shorts/VFnaphZ_vT4



Figure 9: How to insert an SFP into the SFP cage without risking damage to any components on the board.

2.2.3 Voltage Input

The top left connector is the voltage input terminal. A four pin PicoClasp connector is used to allow the input voltage to be easily daisy chained between boards (two wires per power rail).

The voltage input has the following features:

- Voltage input can range from 8 to 60V
- Maximum allowable voltage of 65V
- Transient voltage protection above 66.3V

- Reverse polarity protection

The pinout of the voltage input connector is shown in figure 10 below.

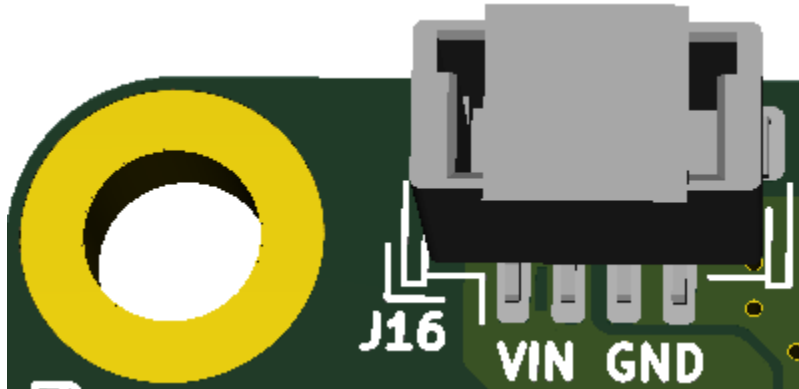

Figure 10: Voltage input header pinout

Connector part numbers

Connector on board	Mating header	Crimp used	Wire used
5019400407	5019390400	5013340000	UL1061, 28AWG

Table 4: Voltage input connector pinout and part numbers

Cable pinout

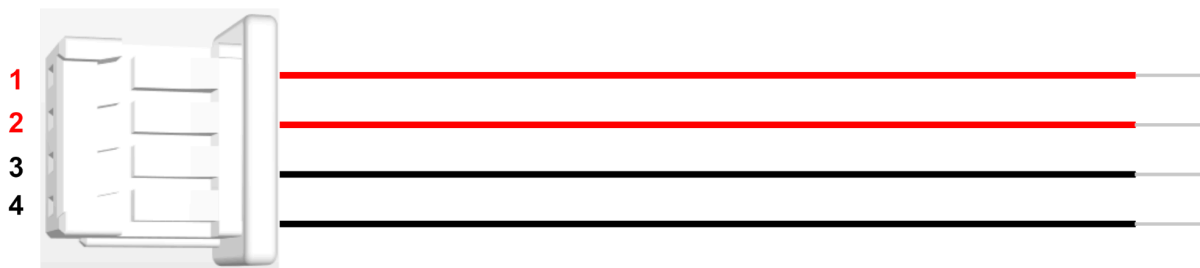

Figure 11: Voltage input cable pinout (red = V+, black = GND)

2.2.4 Ethernet Ports

There are eight ethernet connectors on UbiSwitch Baseboard. Each connector has eight pins corresponding to the eight signals required for 1000BASE-T which are A-, A+, B-, B+, D-, D+, C+, C-. The pin mapping of all eight connectors is identical.

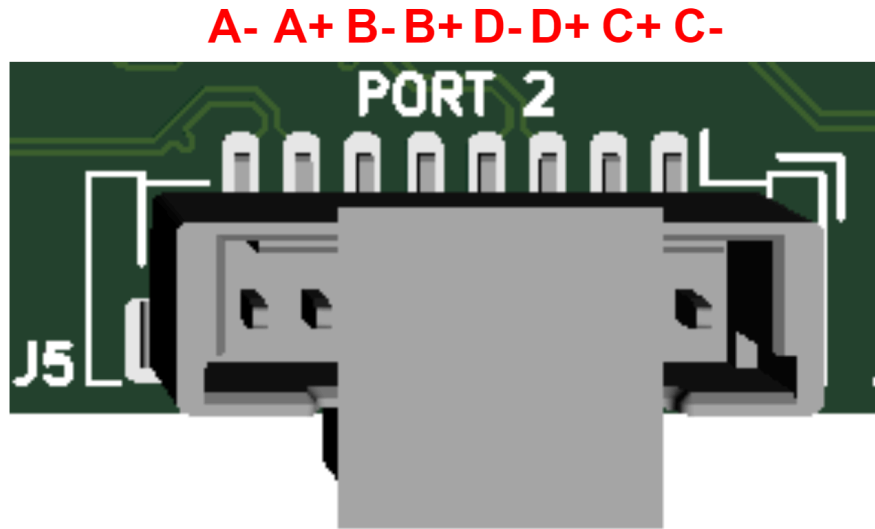

Figure 12: Ethernet port pinout

Connector on board	Mating header	Crimp used	Wire used
5013310807	5013300800	5013340000	UL 1061, 28AWG

Table 5: Ethernet connector pinout and part numbers

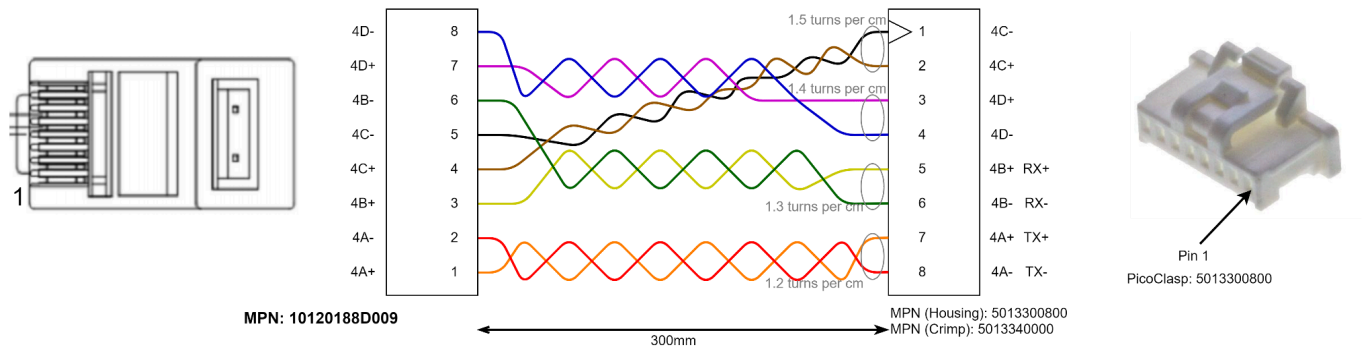

Figure 13: Ethernet cable pinout

2.2.5 External LED Header

An External LED header on the top of the board allows port activity indicator signals can be brought off-board for integration into a chassis

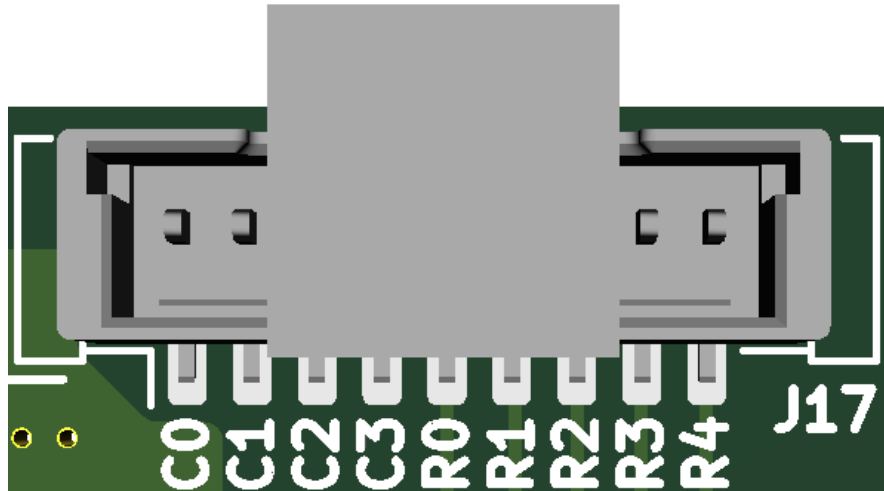

Figure 14: External LED header pinout

Connector on board	Mating header	Crimp used	Wire used
5013310907	5013300900	5013340000	UL1061, 28AWG

Table 6: Ethernet connector pinout and part numbers

External LEDs connection should be followed below diagram:

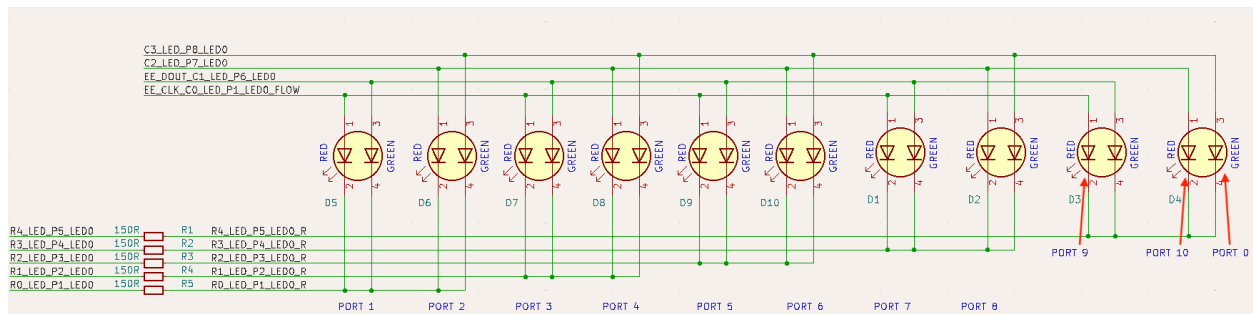

Figure 15: External LEDs connection

Ports 1 to 8 use two LED signals to indicate link speed and activity. In figure 14 above, these two LED signals are mapped to a dual color LED, but this could alternatively be two single color LEDs. In figure 14 above, the color corresponds to the link speed and activity is shown via blinking. (**Red** blinking indicates a 10/100 Mbps connection, **Orange** blink indicates a 1000 Mbps connection). A solid on LED indicates Link/No Activity.

Ports 0, 9 and 10 each use a single LED signal to indicate activity. In the diagram above, Port 10 uses the red part of a dual color LED while Port 0 uses the green part of a dual color LED to save space. Port 9 uses the red green part of another dual color LED.

150Ω resistors are embedded onto the board and hence will already be in series with any external LEDs. This means that additional series resistors may not need to be added to any external LEDs.

2.2.6 SMI header

The SMI header on the top of the board allows access to the registers of Switch IC on the UbiSwitch module, as well as the three SFPs. This header is generally used for troubleshooting, we do not recommend using the SMI header for switch configuration. Instead, use the serial header that provides access to the command line interface on UbiSwitch.

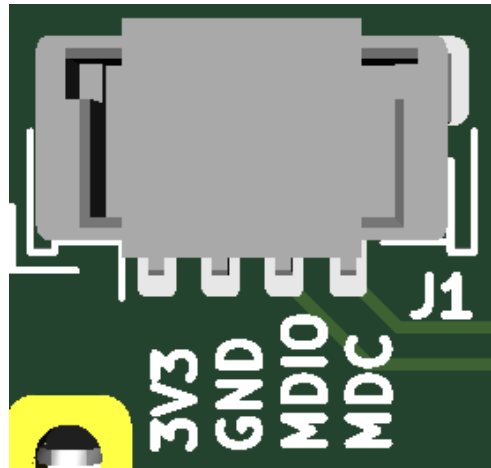

Figure 16: SMI header pinout

Connector on board	Mating header	Crimp used	Wire used
5019400407	5019390400	5013340000	UL1061, 28AWG

Table 7: SMI connector and part numbers

2.2.7 Serial header

The serial header allows control messages to be sent/received to/from the microcontroller on UbiSwitch to configure the device. This allows the user to wire any external serial device to UbiSwitch Baseboard, and send serial commands to the system to provide switch configuration. For more information on this, see section 2.4.3 of the UbiSwitch datasheet.

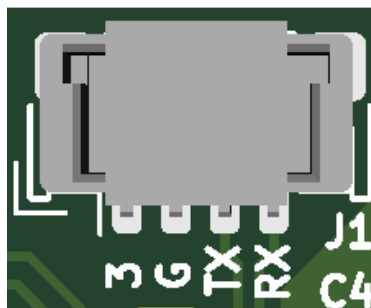

Figure 17: UART header pinout

Connector on board	Mating header	Crimp used	Wire used
5019400407	5019390400	5013340000	UL1061, 28AWG

Table 8: UART connector and part numbers

- TX is an output from UbiSwitch.
- RX is an input to UbiSwitch.
- 3.3V is an output from UbiSwitch, You normally do not need to connect this to an external device. take care connecting this to an external UART converter. Refer to the UbiSwitch CLI Guidelines pdf.
- GND is the ground connection on UbiSwitch.

2.2.8 Synchronous Ethernet Source Clock IPEX header

An IPEX header on the board allows use of the Synchronous Ethernet Source Clock feature. This is a 25 MHz reference clock which can be used as a synchronous clock input to UbiSwitch. This signal must come from a high quality clock conditioning circuit or Synchronous Ethernet PLL. To fully use this feature requires that it be set up in software. By default, this clock is not used.

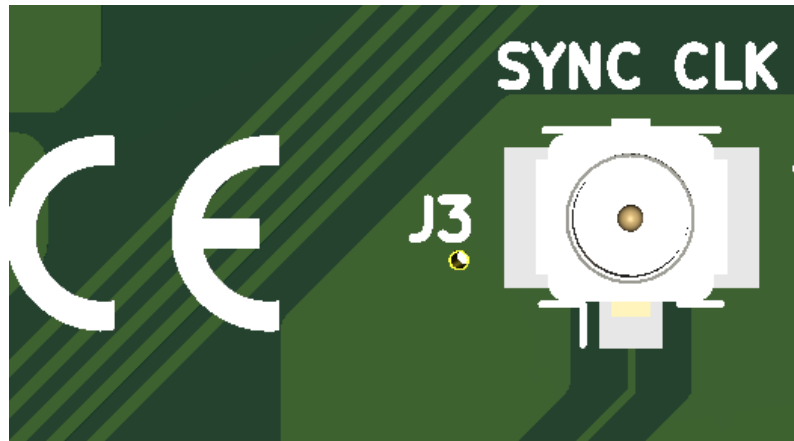

Figure 18: IPEX header

2.3 Other Interfaces

2.3.1 LEDs

There are 15 LEDs on UbiSwitch Baseboard in total. Ten of these LEDs are dual color LEDs, meaning there are a total of twenty-five LED signals on this board. Ten of the LED signals can be taken off board.

The 3.3V SFP+ Power Indicator LED (**Green**) indicates that voltage is present on the 3.3V SFP+ line. It should be solid green in normal operation.

The 3.3V UBI Power Indicator LED (**Green**) indicates that 3.3V of the UbiSwitch module is present. That means the UbiSwitch is stacked on the UbiSwitch Baseboard board correctly and both of them are powered. It should be solid green in normal operation.

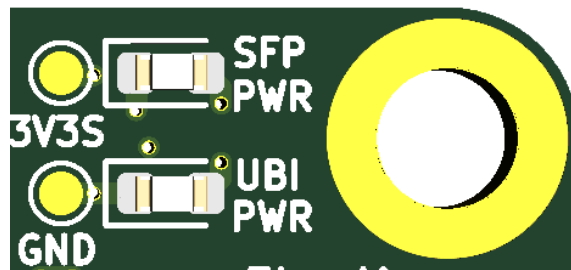

Figure 19: Power Indicator LED

There are three LEDs (**Green**) at bottom left of UbiSwitch Baseboard indicating when SFP+ module is plugged to the SFP+ connector. Each LED indicates one SFP+ module at port 0, 9, 10. It should be solid green when SFP+ module is plugged.

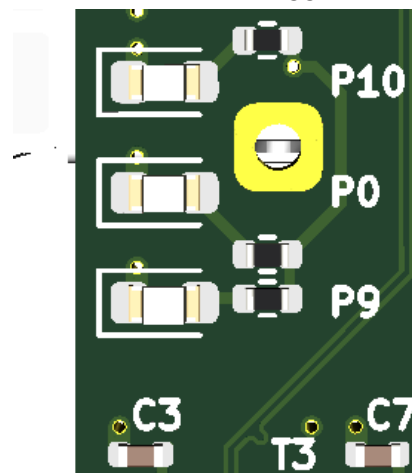

Figure 20: SFP+ module Indicator LED

Each Port from 1 to 8 Activity LED is a **Red/Green** dual color LED and each corresponds to a specific port. They indicate activity on each port and will blink when there is traffic on a port. They should be solid off when a port is not connected to any device, and they should blink under normal operation (**Green** blinking indicates a 1000 Mbps connection, **Red** blinking indicates a 100Mbps connection, **Orange** blink indicates a 10Mbps connection). A solid on LED indicates Link/No Activity.

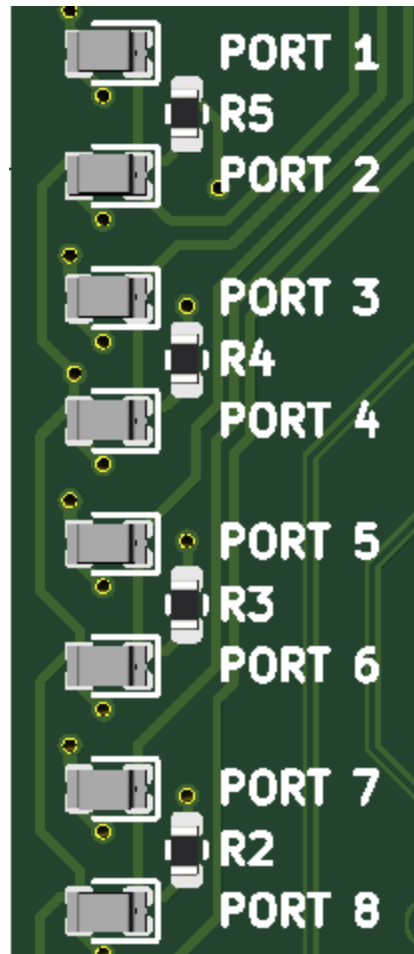

Figure 21: Port 1-8 Link/Activity LEDs

Port 10/0 Activity LED is D4 - **Red/Green** correspondingly. Port 9 activity LED is D3 - **Red**. They should blink under normal operation.

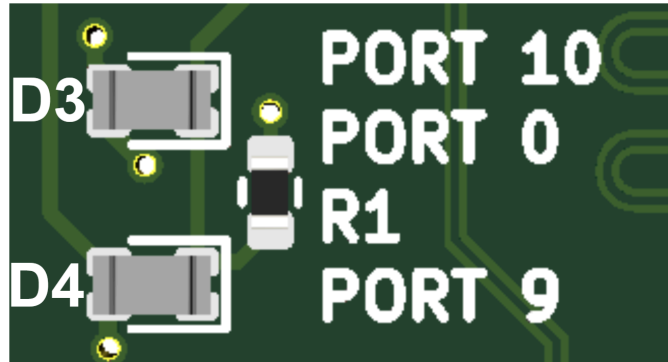

Figure 22: Port 0,9,10 Activity LEDs

2.3.2. Mounting holes

There are six mounting holes on the UbiSwitch Baseboard which are floating by default (not connected to any electrical NET on the board). These holes are designed to accept M3 screws.

Mounting holes 5,6 are used to fix UbiSwitch on UbiSwitch Baseboard, and are populated with board mounted threaded M3 standoffs to allow for easy assembly.

Mounting holes 1,2,3,4 are used to fix UbiSwitch Baseboard to an enclosure. If external access to the shield ground is required on UbiSwitch Baseboard, mounting hole 3 can be connected to UbiSwitch Baseboard's chassis ground by solder bridge jumper JP1. JP1 is open by default.

4 Device Configuration

UbiSwitch Baseboard itself is a passive board and requires no configuration. For information on how to configure UbiSwitch, please refer to the UbiSwitch Datasheet.

5 Mechanical drawing

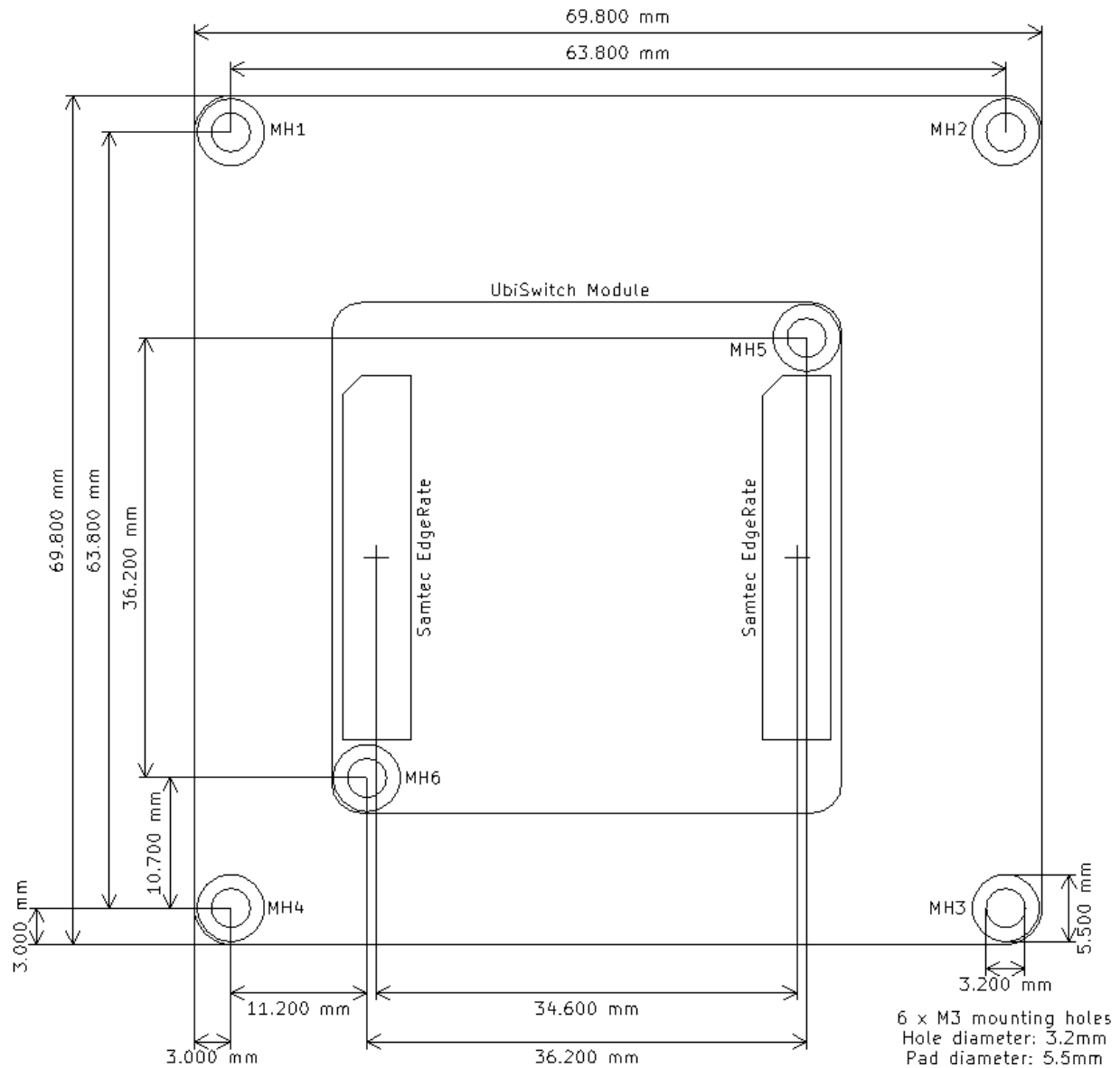

Figure 22. UbiSwitch Baseboard mechanical drawing, viewed from the top down

Full dimensional drawings and 3D CAD can be found in the links below.

<https://botblox.io/content/UbiConn%20Rev%20A%20Dim%20Drawing.pdf>

<https://botblox.io/content/UbiConn%20Rev%20A%20Dim%20Drawing.DXF>

<https://grabcad.com/library/ubiswitch-revision-a-1>

6 Datasheet Changelog

Date	Datasheet Version	Author	Notes
05/02/2023	A_A	Josh Elijah	Initial release
09/02/2023	A_B	Josh Elijah	Updated 4-pin picoclash connector to positive locking type
20/07/2023	A_C	Josh Elijah	Changed name of board from UbiConn to UbiSwitch BaseBoard to be consistent with website naming. Fixed the power error and reference to 10GBlox in the power characteristics. Fixed pinout error in table 3 (previous datasheet version showed pin P6A_N on pin 23, when it should be 52). Figures were correct. Fixed pinout error in table 2 (previous datasheet version showed C2_LED as pin 24, when it should be pin 34). Figures were correct.
31/07/2023	A_D	Josh Elijah	Added note that only 10G SFPs can be used.
10/07/2023	A_E	Josh Elijah	Added note about stiff SFP cages
25/10/2023	A_F	Jaclyn Li	Table 1.1.2 General Information updated to be correct values
14/11/2023	A_G	Josh Elijah	Fixed incorrectly labeled SFP LED indicators
01/05/2024	A_H	Jaclyn Li	Updated operating temperature range from “-40°C to +85°C” to “-70°C to +110°C”. Updated storage temperature range from “-40°C to +125°C” to “-70°C to +125°C”.
10/05/2024	B_H	Josh Elijah	Forked version of datasheet to support revision B of UbiSwitch Baseboard.
20/06/2024	B_I	Josh Elijah	Fixed the incorrect LED information saying that an orange LED indicates a 10Mbps connection. Fixed cables included in “1.4 Included Equipment”.

Date	Datasheet Version	Author	Notes
05/02/2023	A_A	Josh Elijah	Initial release
09/02/2023	A_B	Josh Elijah	Updated 4-pin picoclash connector to positive locking type
20/07/2023	A_C	Josh Elijah	Changed name of board from UbiConn to UbiSwitch BaseBoard to be consistent with website naming. Fixed the power error and reference to 10GBlox in the power characteristics. Fixed pinout error in table 3 (previous datasheet version showed pin P6A_N on pin 23, when it should be 52). Figures were correct. Fixed pinout error in table 2 (previous datasheet version showed C2_LED as pin 24, when it should be pin 34). Figures were correct.
27/02/2025	B_D	Josh Elijah	Added additional information about the 3.3V UART port.
07/03/2025	B_E	Jaclyn Li	Updated 1.4 cables included

7 Contact

If you have any questions regarding this product, please contact us:

info@botblox.org

4 Pavilion Court 600 Pavilion Drive,
Northampton Business Park,
Northampton,
England
NN4 7SL

8 Certificate of Conformity

The full text of the Certificate of Conformity of this product is available at the following web address. <https://botblox.io/documentation/>