

# SwitchBlox Industrial

## Small 5 port 10/100Mbps Ethernet Switch

MPN: BB-SWI-A-1

**Datasheet**

October 2022  
Board revision A

# Contents

<b>Contents</b>	<b>2</b>
<b>1 General Information</b>	<b>3</b>
1.1 Functionality and Features of SwitchBlox Industrial	3
1.2 Safety Information	5
1.3 Block Diagram	5
1.4 Included Equipment	6
1.5 RoHS Certification of Compliance	6
<b>2 Hardware Interfaces</b>	<b>7</b>
2.1 Board Map	7
2.2 Connectors and Pinouts	8
2.2 Other Interfaces	13
<b>3 Software Interfaces</b>	<b>15</b>
3.1 SMI (Serial Management interface)	15
3.2 UART	15
<b>4 Device Configuration</b>	<b>16</b>
4.1 Unmanaged Switch	16
4.2 Managed Switch	16
<b>5 Device Characteristics</b>	<b>17</b>
5.1 Operating Conditions	17
<b>6 Datasheet Changelog</b>	<b>18</b>
<b>7 Contact</b>	<b>18</b>

# 1 General Information

## 1.1 Functionality and Features of SwitchBlox Industrial

The BotBlox SwitchBlox Industrial is a small form factor 5 port 10/100Mbps (10BASE-T/100BASE-TX) Layer 2 unmanaged and lightly managed ethernet switch. It has a non-blocking fabric, meaning that 100Mbps speed can be achieved simultaneously on all ports. SwitchBlox Industrial is designed to be a more rugged and more capable upgrade to our SwitchBlox product and is designed for space, weight and price-sensitive (SWaP) industrial, mobile applications.

It runs from a wide input voltage range of 6.5 to 60V, and provides a 5A, 2A power output. It also features PoE injection onboard, and houses a microcontroller for custom firmware upload.

### 1.1.1 Features

- 5 x 10/100M (10BASE-T/100BASE-TX) ethernet ports
- Input voltage range from 6.5 to 60V
- Reverse protected voltage input
- Transient protected voltage input
- -40°C to +85°C operation range
- 38mm x 38mm board size
- Molex Picoblade connectors for power and ports
- 15W PoE injection on each port (selectable via a DIP switch)
- Automatic MDI-X crossover
- Unmanaged (out-the-box) functionality
- Embedded STM32L011F4U6 onboard for firmware to implement managed switch functions (VLANs, QoS, Port Mirroring)
- Programmable RGB LED (via STM32)

### 1.1.2 General Information

<b>Voltage Input</b>	5V to 60V DC (65V absolute max)
<b>Voltage Output</b>	5V $\pm$ 5%, 2A
<b>PoE Maximum Power Output</b>	15W (IEEE 802.3af)
<b>Supported Protocols</b>	10BASE-T, 100BASE-TX
<b>Power Consumption</b>	260mW (idle) to 400mW (full switching)
<b>Weight</b>	15 grams
<b>Size</b>	38 mm x 38 mm x 9.2 mm
<b>Operating Temperature</b>	-40°C to +85°C
<b>Storage Temperature</b>	-40°C to +85°C

*Table 1: General Information*

### 1.1.3 General Operating Instructions

SwitchBlox Industrial is designed for use in harsh environments, operating from a nominal supply voltage of 24V, but with the ability to operate from as low as 6.5V and as high as 60V.

In the simplest case of an unmanaged switch application, SwitchBlox Industrial can be operated immediately by following the following steps.

- 1) Apply a voltage between 6.5V to 60V to the voltage input terminals.
- 2) Connect external devices to the ethernet ports using RJ45 to Picoblade cables.
- 3) SwitchBlox Industrial will automatically begin auto negotiation with connected devices and begin receiving and forwarding packets to/from all connected devices.

In managed mode SwitchBlox Industrial can implement VLAN setup, port mirroring and QoS.

*Other methods of operation are possible by uploading firmware to the STM32L011F4U6 on SwitchBlox Industrial.*

*By default SwitchBlox Industrial ships without any firmware.*

## 1.2 Safety Information

- This device can operate on voltages near and above 60V. Please read this manual before operating.
- This device is provided “as is”. In-application testing prior to integration is recommended.
- This device is provided as an electronic circuit board, and requires integration into chassis for full ingress protection.
- Do not use this product in wet environments without integrating into a chassis.
- Do not operate this product beyond the rated temperature and voltages.
- The board temperature can reach 40°C above ambient when 2A is drawn from the 5V output. In such cases, passive air cooling or heat sinking should be considered.

## 1.3 Block Diagram

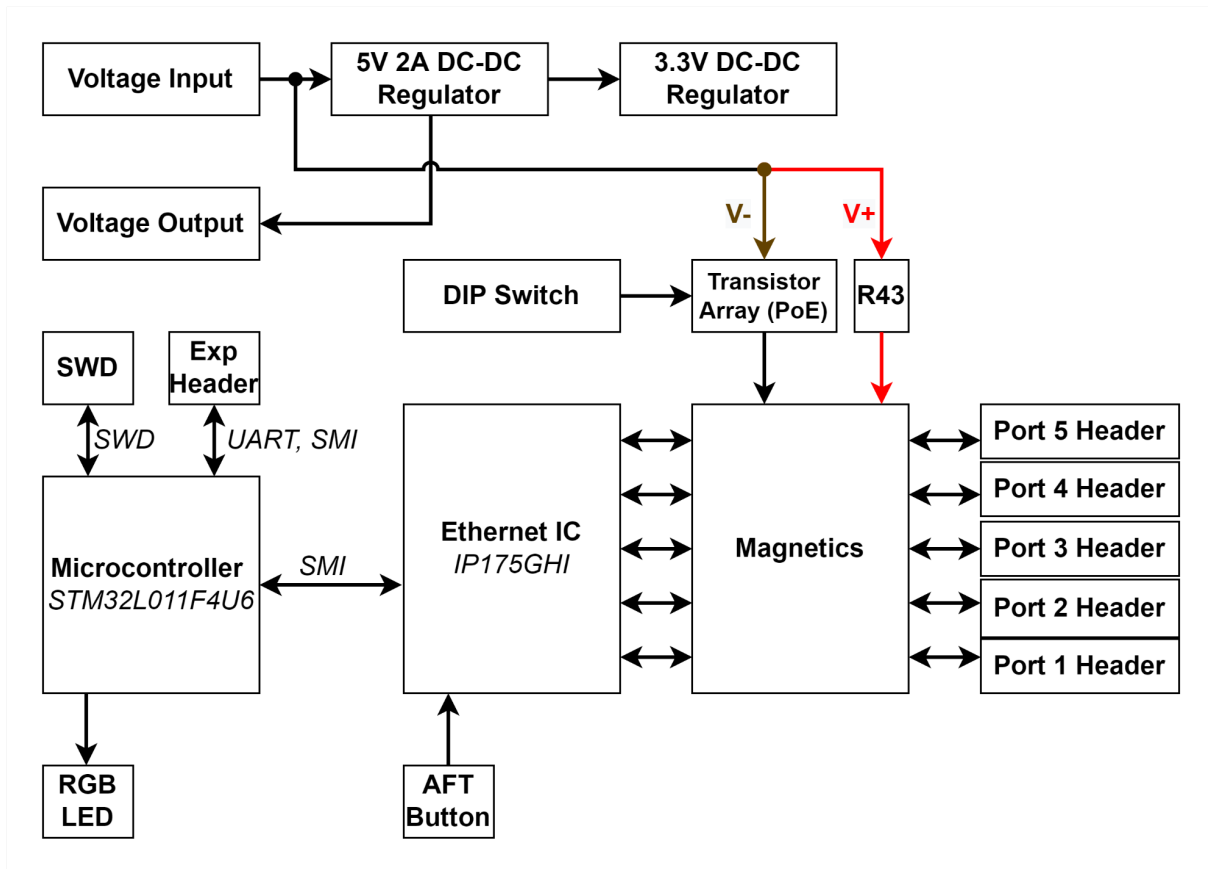

Figure 1: SwitchBlox Industrial Block Diagram

## 1.4 Included Equipment

The product includes the following:

1 x SwitchBlox Industrial board

5 x Molex Picoblade to RJ45 4-way Unshielded Twisted Pair cables (300mm)

2 x Molex Picoblade to bare, tinned leads (300mm)

## 1.5 RoHS Certification of Compliance

The BotBlox SwitchBlox Industrial complies with the RoHS (Restriction of Hazardous Substances Directive) Certificate of Compliance.

## 2 Hardware Interfaces

### 2.1 Board Map

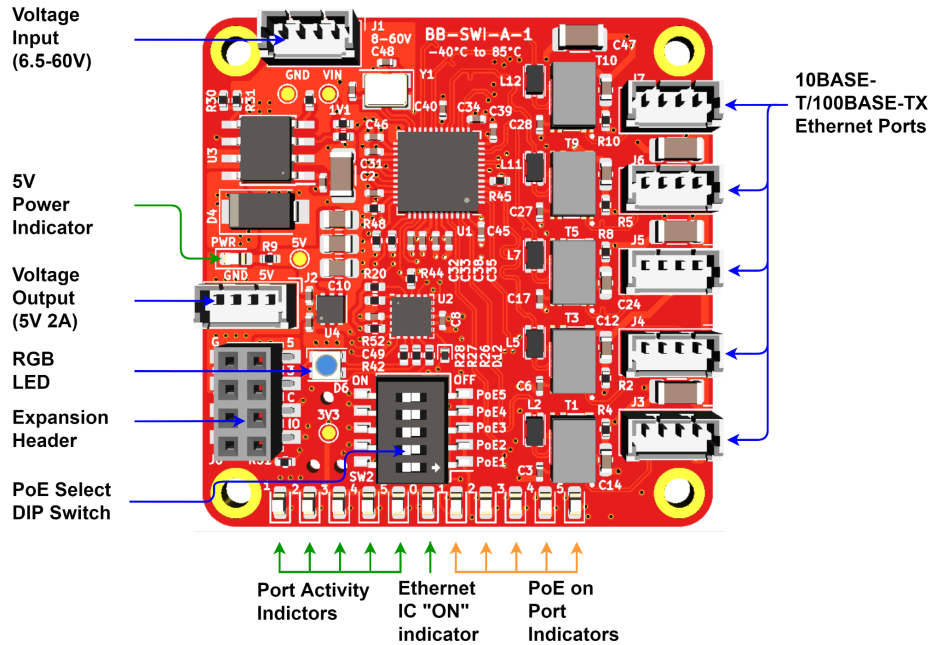

Figure 2: SwitchBlox Industrial Board Map (front)

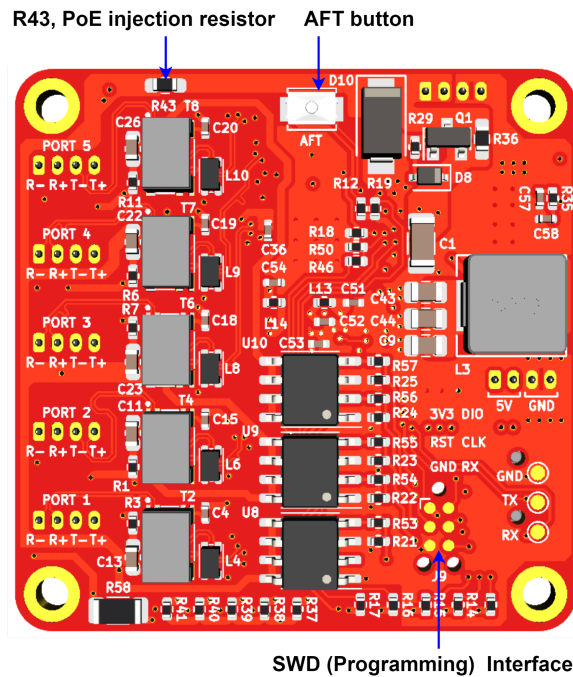

Figure 3: SwitchBlox Industrial Board Map (back)

## 2.2 Connectors and Pinouts

### 2.1.1 Voltage Input

The top left connector is the voltage input terminal. A four pin connector is used to allow the input voltage to be easily daisy chained between boards (two wires per power rail).

The voltage input has the following features:

- Voltage input can range from 6.5 to 60V
- Maximum allowable voltage of 65V
- Transient voltage protection above 66.3V
- Reverse polarity protection

The pinout of the voltage input connector is shown in Figure 4 below.

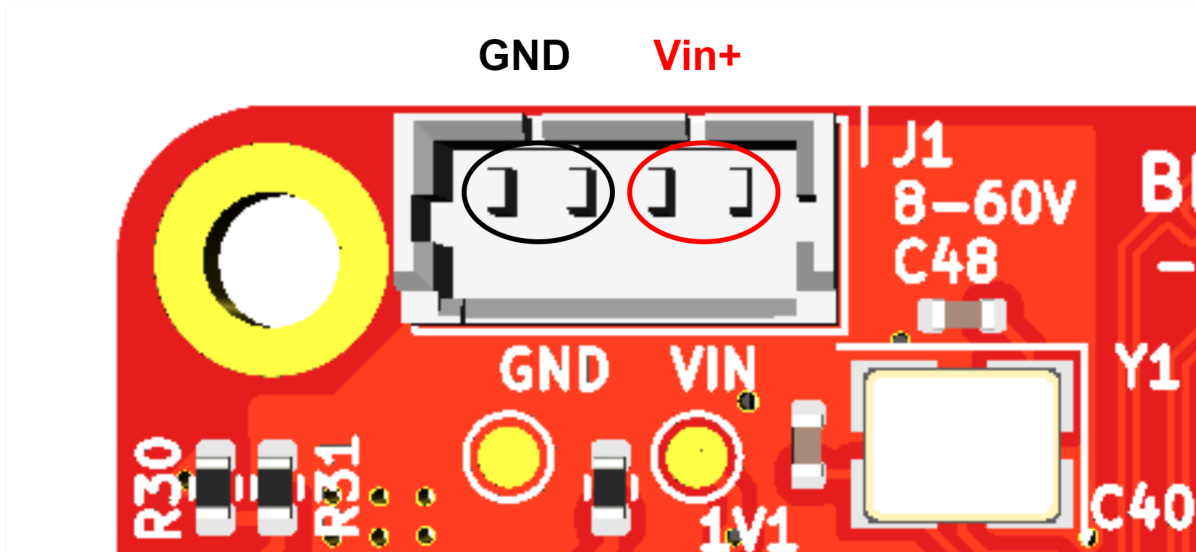

Figure 4: Voltage input header pinout

Connector part numbers

Connector on board	Mating header	Crimp used	Wire used
<a href="#">530470410</a>	<a href="#">0510210400</a>	<a href="#">500798000</a>	UL1061, 28AWG

Table 2: Voltage input connector pinout and part numbers



### Cable pinout

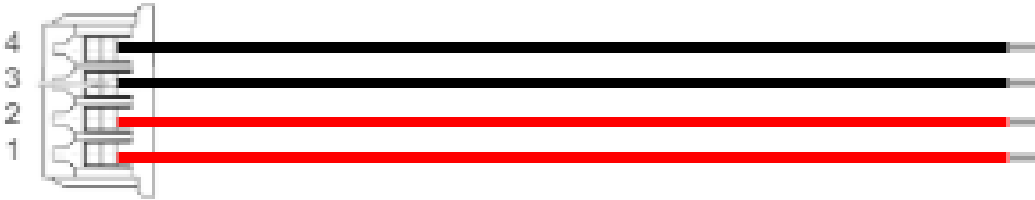

Figure 5: Voltage input cable pinout (red = V+, black = GND)

### 2.1.2 Voltage Output

The middle left connector is the voltage output terminal. A four pin connector is used to increase the maximum output current.

The voltage output has the following features:

- Voltage output is nominally 5V with tolerance of  $\pm 5\%$
- Up to 2A output current
- Around 132 $\mu$ F of capacitance on the 5V rail

The pinout of the voltage output connector is shown in Figure 6 below.

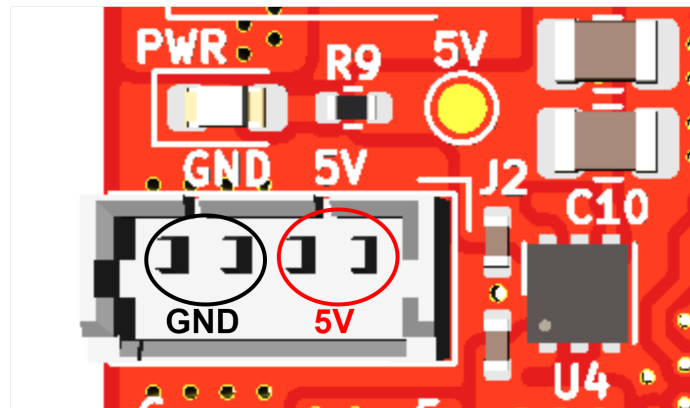

Figure 6: Voltage output header pinout

### Cable pinout

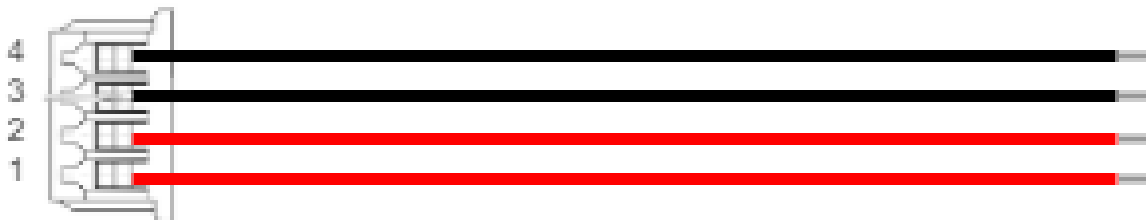

Figure 7: Voltage input cable pinout (red = 5V, black = GND)

### Connector part numbers

Connector on board	Mating header	Crimp used	Wire used
<a href="#">530470410</a>	<a href="#">0510210400</a>	<a href="#">500798000</a>	UL1061, 28AWG

Table 3: Voltage output connector pinout and part numbers

### 2.1.3 Ethernet Ports

There are five ethernet connectors on SwitchBlox Industrial. Each connector has four pins corresponding to the four signals required for 100BASE-TX which are T+, T-, R+ and R-. The pin mapping of all five connectors is identical.

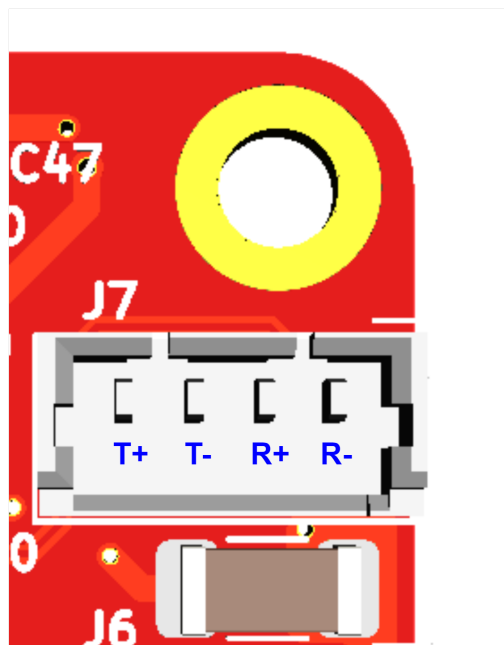

Figure 8: Ethernet port pinout

Connector on board	Mating header	Crimp used	Wire used
<a href="#">530470410</a>	<a href="#">0510210400</a>	<a href="#">500798000</a>	UL1061, 28AWG

Table 4: Ethernet connector pinout and part numbers

### Cable pinout

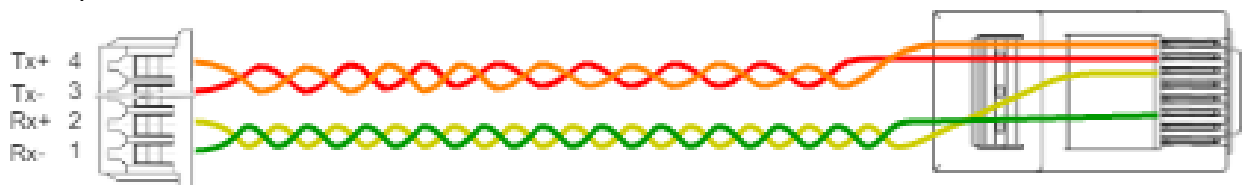

Figure 9: Ethernet cable pinout

### 2.1.4 Extension header

SwitchBlox Industrial boards have an extension header for switch management. The extension header provides the following interfaces:

- UART (TX and RX) connected to PA1 (LPUART1\_TX) and PA0 (LPUART1\_RX) on the STM32 microcontroller.
- SMI/I2C connected to PB6 (MDC) and PB7 (MDIO) on the STM32 microcontroller; also connected to the MDC and MDIO pins on the IP175GHI.
- Onboard 5V output rail (can be used to supply power to the board).
- Onboard 3V3 rail (can be used to supply power to the board).

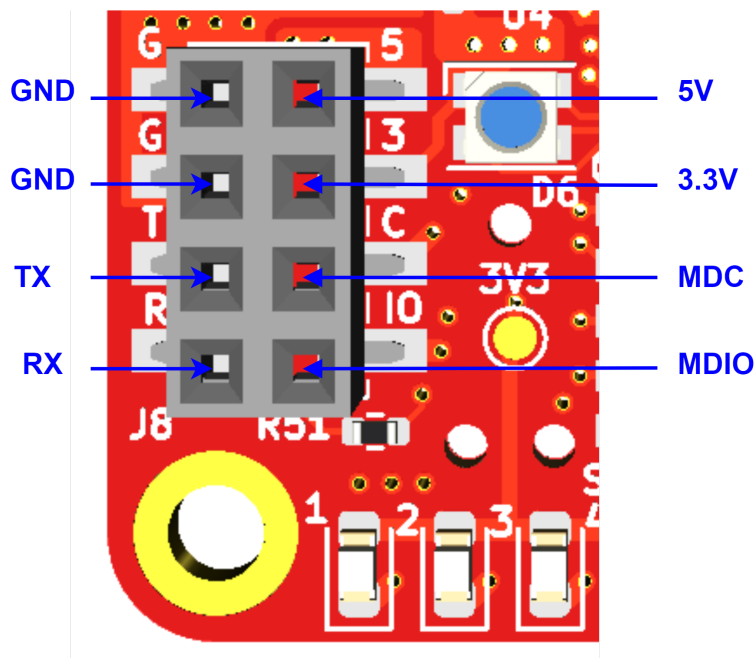

Figure 10: Extension header pinout

The part number for the extension header is [NPPN042FFKP-RC](#), the mating part for this header is [NRPN042PAEN-RC](#).

### 2.1.5 SWD Programming Header

A programming header on the back of the board allows the STM32L011F4U6 on SwitchBlox Industrial to be programmed over SWD.

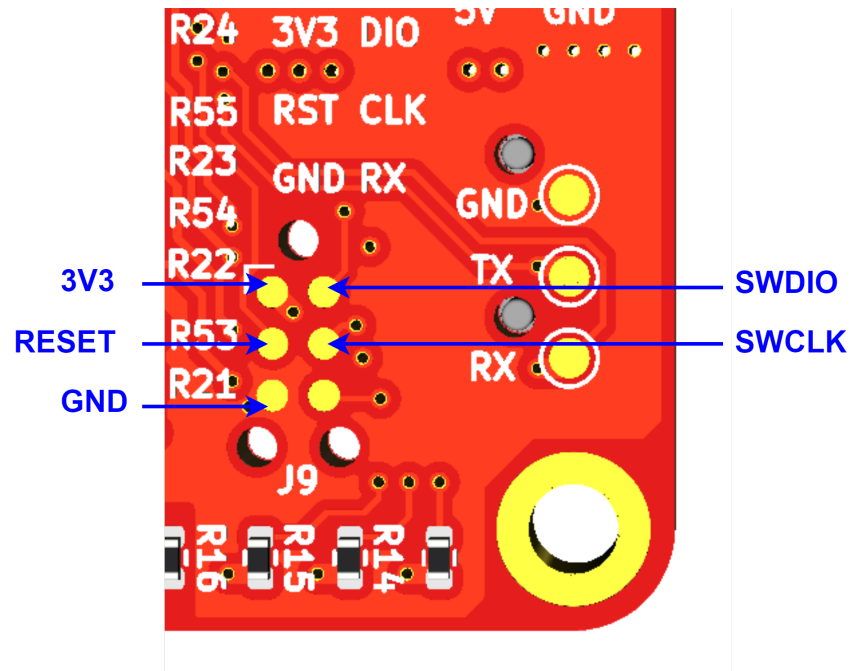

Figure 11: SWD programming header pinout

This header allows access to the SWD port on the onboard STM32 microcontroller, and requires the use of a 6-pin needle adapter such as the [J-Link 6-pin needle adapter](#) along with an in-circuit programmer such as the [J-Link](#).

## 2.2 Other Interfaces

### 2.2.1 DIP Switch for PoE Injection

A DIP switch on the back of SwitchBlox Industrial allows the input voltage to be injected onto any of the ports. To achieve IEEE 802.3af compliant PoE on the port, an input voltage between 44V to 48V is needed. Once active, each PoE port can deliver a maximum of 300mW. PoE is not enabled by default. To enable, R43 needs to be populated with a 0603 0 ohm resistor.

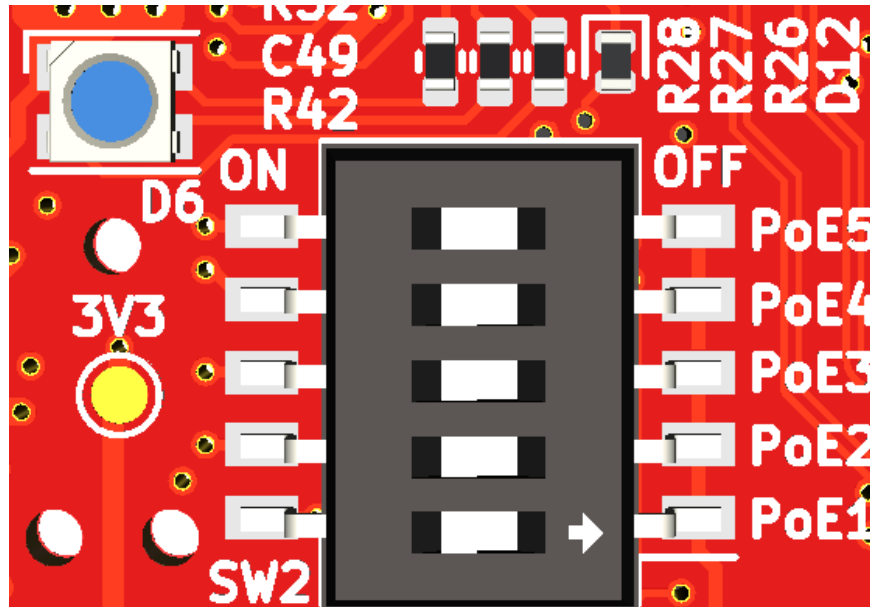

Figure 12: PoE select DIP switch

In the right-most position, the ethernet ports are not PoE enabled. In the left most position, the input voltage is injected onto the selected port, and the corresponding PoE port LED turns on to indicate PoE voltage on the board.

*PoE injection is not a “hot-swappable feature”. Only toggle PoE on a port when no load is applied. If PoE is toggled while a load is connected, the PoE will be stuck on.*

*Drawing 300mW from all PoE ports at the same time can lead to the board overheating. It is best to test this in the application first.*

*Resistor R43 must be populated with a 0 Ohm resistor to enable the PoE feature. This resistor is depopulated by default.*

The pinout of PoE on the port pins is TX+/TX- DC Voltage = 0V, RX+/RX- DC Voltage = Vin.

### 2.2.2 LEDs

There are 12 LEDs on SwitchBlox Industrial in total. None of the LED signals can be taken off board.

The 5V Power Indicator LED (**Green**) indicates that voltage is present on the 5V line. It should be solid green in normal operation.

The Ethernet IC “ON” Indicator LED (**Green**) indicates that the ethernet IC is powered up and working. It should be solid green in normal operation.

Each Port Activity LED (**Green**) corresponds to a specific port. They indicate activity on each port and will blink when there is traffic on a port. They should be solid off when a port is not connected to any device, and they should blink under normal operation. A solid green LED indicates either constant traffic, or a fault with the port.

The PoE on Port Indicator LEDs (**Orange**) indicates which of the ports currently has PoE injected onto it. This can be toggled on a port-by-port basis using the PoE Select DIP switch.

## 3 Software Interfaces

### 3.1 SMI (Serial Management interface)

SwitchBlox uses the IP175GHI to perform the ethernet switching. The IP175GHI is an integrated 5 port ethernet switch, which also supports managed functions such as QoS, Port Mirroring and VLAN management (amongst other functions). By default the IC runs as an unmanaged switch. Managed functions need to be configured via SMI.

SMI (also known as MDIO) is a board-level serial interface that is commonly used for configuring ethernet ICs. On a physical level it is very similar to I2C however it uses a slightly different data structure. For the purposes of this document, SCL (I2C serial clock) will be used interchangeably with MDC (management data clock) and SDA (I2C serial data) will be used interchangeably with MDIO (management data input/output). This is the case for the labelling on the breakout header too.

On SwitchBlox Industrial MDC and MDIO connect to the STM32L011F4U6 pins. PB6 connects to MDC, PB7 connects to MDIO. This allows the STM32 to programmatically control the IP175GHI, and implement custom managed switch features. BotBlox have developed custom firmware for this application which can be found on <https://www.botblox.io/>.

### 3.2 UART

Pins PA0 (LPUART1\_RX) and PA1 (LPUART1\_TX) on the onboard STM32L011F4U6 are exposed on the expansion header. Given that the STM32 is also connected to the IP175GHI ethernet switch, this allows any external device to control the functionality of the onboard ethernet switch via custom parser software running on the STM32.

BotBlox have developed custom software for this application which can be found on <https://www.botblox.io/>.

## 4 Device Configuration

### 4.1 Unmanaged Switch

To use SwitchBlox Industrial in an unmanaged application requires no configuration. Simply connect a voltage to the voltage input and connect downstream devices.

### 4.2 Managed Switch

Running SwitchBlox Industrial in a managed switch application requires configuring the IP175GHI onboard over SMI. This can be done via custom firmware on STM32, or directly connecting an external device to SwitchBlox Industrial over SMI.

The IP175GHI only has volatile memory, meaning configuration is only stored while power is active. This means it is necessary to write the configuration to the IP175GHI on every startup. The STM32 onboard is able to circumvent this limitation by storing configuration variables in its internal EEPROM and then write this to the IP175GHI at power on. This is how the BotBlox firmware works, and it allows configurations to be stored even after power off.

You can find this firmware on <https://www.botblox.io/>.



## 5 Device Characteristics

### 5.1 Operating Conditions

#### 5.1.1 Absolute Maximum Ratings

Operating in these ranges will reduce the lifetime of the device.

<b>Voltage Input Maximum</b>	65V
<b>PoE Current Delivery (per port)</b>	350mA
<b>Storage Temperature</b>	-40°C to +85°C
<b>Operating Temperature</b>	-40°C to +85°C
<b>5V Output Current</b>	2.3A

#### 5.1.2 Nominal (Test) Ratings

<b>Voltage Input</b>	65V
<b>PoE Power Delivery (per port)</b>	0mA
<b>5V Output Current</b>	0mA

## 6 Datasheet Changelog

Date	Datasheet Version	Author	Notes
01/10/2022	A_A	Josh Elijah	Initial release
21/05/2023	A_B	Josh Elijah	Updated voltage input range from 6.5V to 5V minimum

## 7 Contact

If you have any questions regarding this product, please contact us:

info@botblox.io  
4 Pavilion Court 600 Pavilion Drive,  
Northampton Business Park,  
Northampton,  
England  
NN4 7SL