

# SwitchBlox

Small 5 port 10/100Mbps  
Ethernet Switch

## Datasheet

Applies to:

MPN: BB-SWB-E-1

MPN: BB-SWB-E-1-NDAA

May 2024

Board revision E/F

# Contents

<b>Contents</b>	<b>2</b>
<b>1 General Information</b>	<b>2</b>
1.1 Functionality and Features of SwitchBlox	2
1.2 Safety Information	4
1.3 Block Diagram	4
1.4 Included Equipment	4
1.5 RoHS Certification of Compliance	4
1.6 Board Revisions	4
<b>2 Hardware Interfaces</b>	<b>6</b>
2.1 Board Map	6
2.2 Connectors and Pinouts	6
2.2 Other Interfaces	11
<b>3 Software Interfaces</b>	<b>13</b>
3.1 MDIO	13
<b>4 Device Configuration</b>	<b>14</b>
4.1 Unmanaged Switch	14
<b>5 Device Characteristics</b>	<b>14</b>
5.1 Operating Conditions	14
<b>6 Datasheet Changelog</b>	<b>15</b>
<b>7 Contact</b>	<b>17</b>
<b>8 Certificate of Conformity</b>	<b>17</b>

# 1 General Information

## 1.1 Functionality and Features of SwitchBlox

The BotBlox SwitchBlox is a small form factor 5 port 10/100Mbps (10BASE-T/100BASE-TX) unmanaged ethernet switch. It has a non-blocking fabric, meaning that 100Mbps speed can be achieved simultaneously on all ports.

It runs from a wide input voltage range of 5.1 to 60V, and provides a 5A, 2A power output.

### 1.1.1 Features

- 5 x 10/100M (10BASE-T/100BASE-TX) ethernet ports
- Input voltage range from 5.1 to 60V
- Reverse protected voltage input
- Transient protected voltage input
- 45mm x 45mm board size
- Molex Picoblade connectors for power and ports
- Automatic MDI-X crossover
- Unmanaged (out-the-box) functionality

### 1.1.2 General Information

<b>Voltage Input</b>	5V to 60V DC (65V absolute max) (Reverse Protected)
<b>Voltage Output</b>	5V $\pm$ 5%, 2A
<b>Supported Protocols</b>	10BASE-T, 100BASE-TX
<b>Power Consumption</b>	300mW (idle) to 700mW (full switching)
<b>Weight</b>	15 grams
<b>Size</b>	44.5 mm x 44.5 mm x 11.3 mm
<b>Operating Temperature</b>	-10°C to +80°C
<b>Storage Temperature</b>	-65°C to +150°C

Table 1: General Information

### 1.1.3 General Operating Instructions

SwitchBlox is designed for use in commercial and industrial environments, operating from a nominal supply voltage of 24V, but with the ability to operate from as low as 5.1V and as high as 60V.

In the simplest case of an unmanaged switch application, SwitchBlox can be operated immediately by following the following steps.

- 1) Apply a voltage between 5.1V to 60V to the voltage input terminals.
- 2) Connect external devices to the ethernet ports using RJ45 to Picoblade cables.
- 3) SwitchBlox will automatically begin auto negotiation with connected devices and begin receiving and forwarding packets to/from all connected devices.

### 1.2 Safety Information

- This device can operate on voltages near and above 60V. Please read this manual before operating.
- This device is provided “as is”. In-application testing prior to integration is recommended.
- This device is provided as an electronic circuit board, and requires integration into chassis for full ingress protection.
- Do not use this product in wet environments without integrating into a chassis.
- Do not operate this product beyond the rated temperature and voltages.
- The board temperature can reach 60°C when 2A is drawn from the 5V output. In such cases, passive air cooling or heat sinking should be considered.

### 1.3 Block Diagram

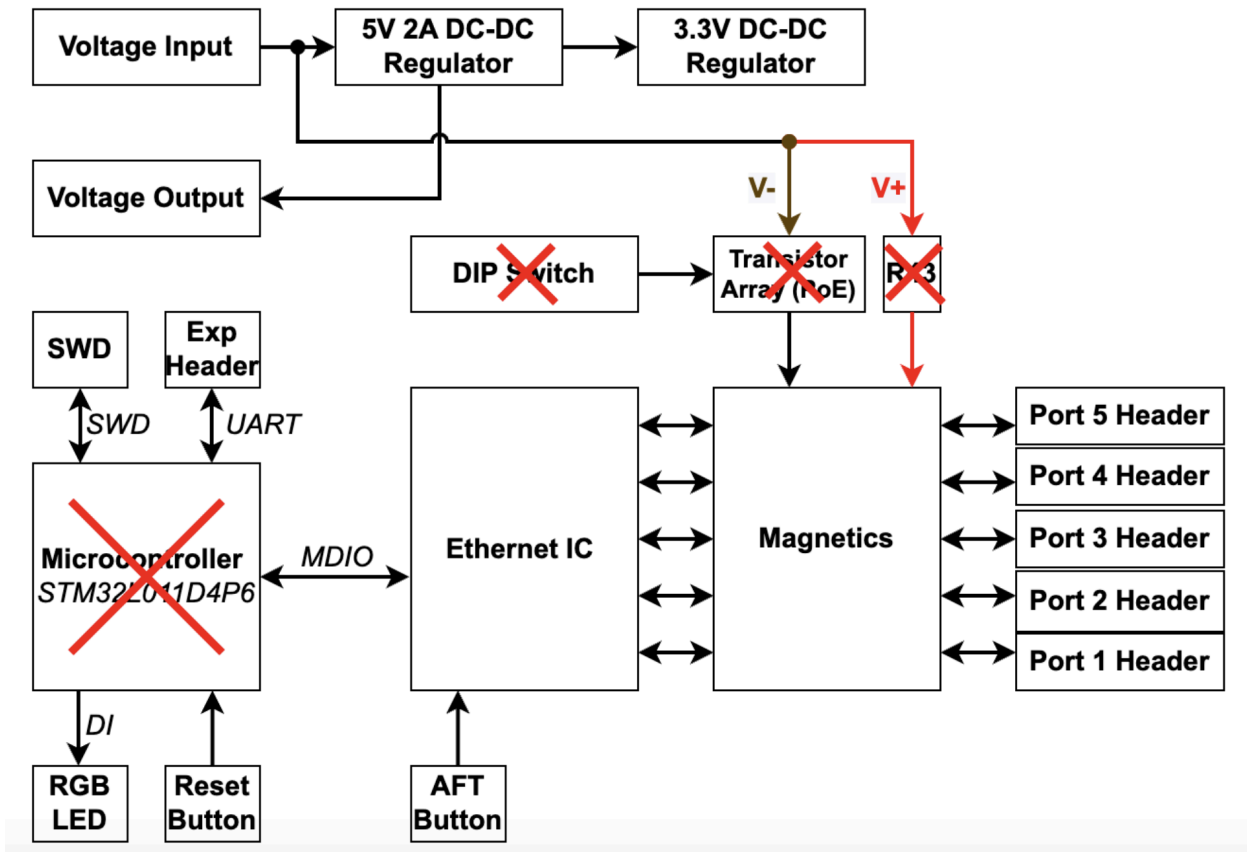

Figure 1: SwitchBlox Block Diagram

### 1.4 Included Equipment

The product includes the following:

- 1 x SwitchBlox board
- 5 x Molex Picoblade to RJ45 4-way Unshielded Twisted Pair cables (300mm)
- 2 x Molex Picoblade to bare, tinned leads (300mm)

### 1.5 RoHS Certification of Compliance

The BotBlox SwitchBlox complies with the RoHS (Restriction of Hazardous Substances Directive) Certificate of Compliance.

## 1.6 Board Revisions

The information in this datasheet applies to revision E and F. Both revisions are functionally identical, however rev F has the following changes:

- Boot button on Rev E is replaced with a microcontroller reset button on Rev F.
- PoE injection resistor R43 is not populated on Rev F. R43 is populated on Rev E. This resistor injects voltage onto the transformer TX pairs which can cause power issues when connected with downstream devices that have circuitry directly on the ethernet lines. R43 was depopulated in Rev F to prevent potential problems.
- PoE circuitry has been removed.
- STM32 microcontroller is not present.

## 2 Hardware Interfaces

### 2.1 Board Map

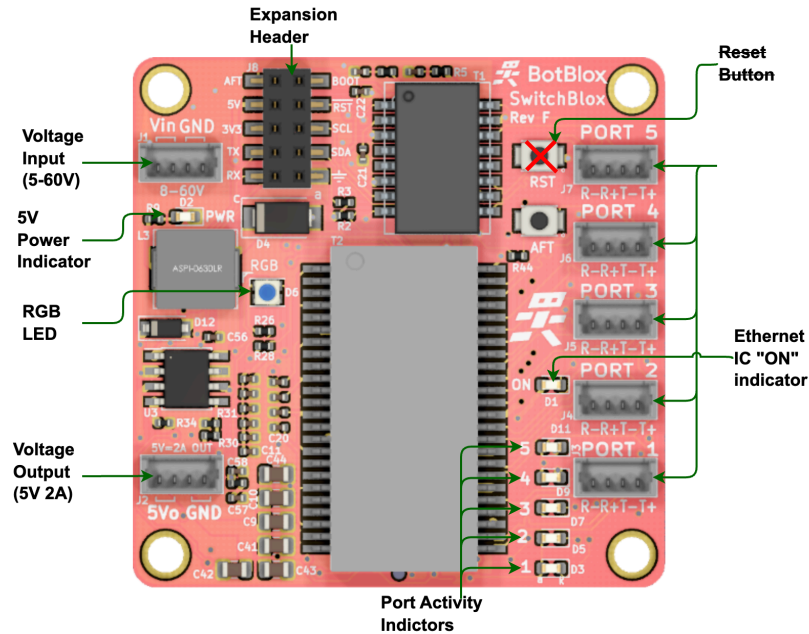

Figure 2: SwitchBlox Board Map (front)

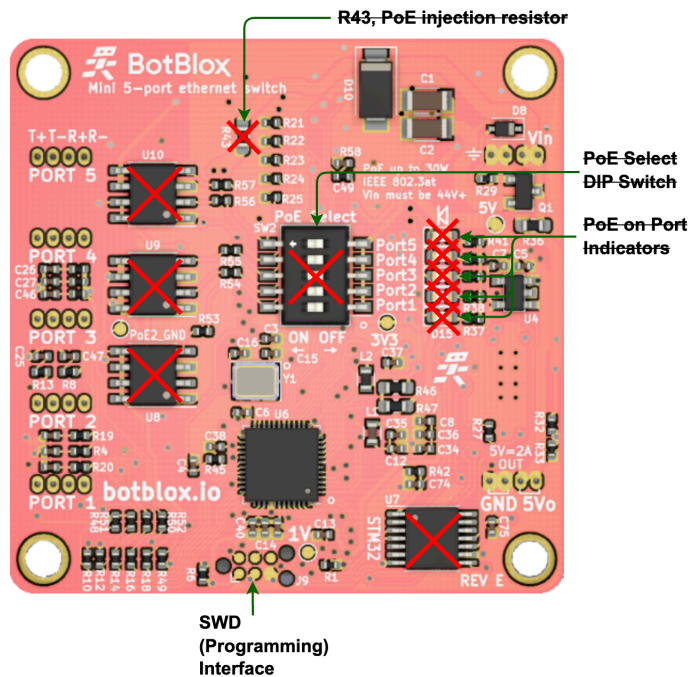

Figure 3: SwitchBlox Board Map (back)

## 2.2 Connectors and Pinouts

### 2.1.1 Voltage Input

The top left connector is the voltage input terminal. A four pin connector is used to allow the input voltage to be easily daisy chained between boards (two wires per power rail).

The voltage input has the following features:

- Voltage input can range from 5 to 60V
- Maximum allowable voltage of 65V
- Transient voltage protection above 66.3V
- Reverse polarity protection

The pinout of the voltage input connector is shown in figure 4 below.



Figure 4: Voltage input header pinout

Connector part numbers

Connector on board	Mating header	Crimp used	Wire used
<a href="#">530470410</a>	<a href="#">0510210400</a>	<a href="#">500798000</a>	UL1061, 28AWG

Table 2: Voltage input connector pinout and part numbers



### Cable pinout

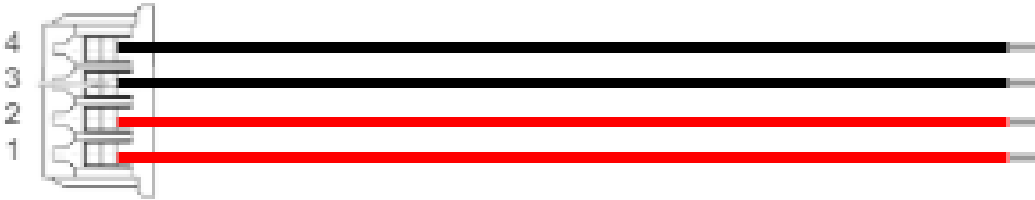

Figure 5: Voltage input cable pinout (red = V+, black = GND)

### 2.1.2 Voltage Output

The bottom left connector is the voltage output terminal. A four pin connector is used to increase the maximum output current.

The voltage output has the following features:

- Voltage output is nominally 5V with tolerance of  $\pm 5\%$
- Up to 2A output current
- Around 132 $\mu$ F of capacitance on the 5V rail

The pinout of the voltage output connector is shown in figure 6 below.

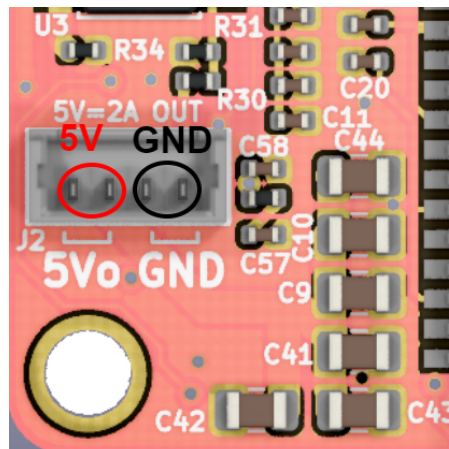

Figure 6: Voltage output header pinout

### Cable pinout

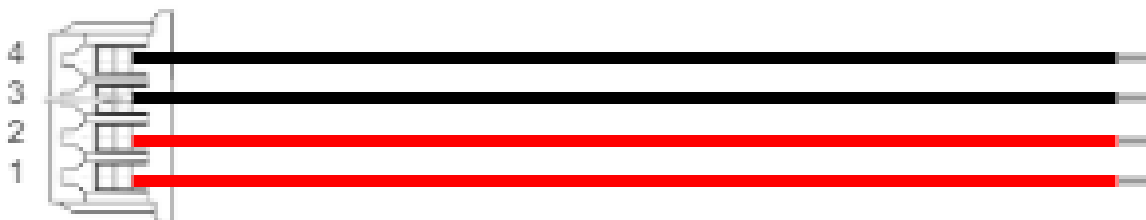

Figure 7: Voltage input cable pinout (red = 5V, black = GND)

### Connector part numbers

Connector on board	Mating header	Crimp used	Wire used
<a href="#">530470410</a>	<a href="#">0510210400</a>	<a href="#">500798000</a>	UL1061, 28AWG

Table 3: Voltage output connector pinout and part numbers

### 2.1.3 Ethernet Ports

There are five ethernet connectors on SwitchBlox. Each connector has four pins corresponding to the four signals required for 100BASE-TX which are R+, R-, T- and T+. The pin mapping of all five connectors is identical.

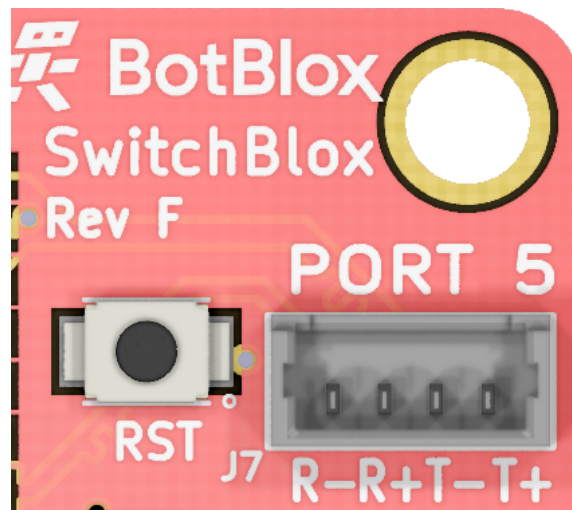

Figure 8: Ethernet port pinout

Connector on board	Mating header	Crimp used	Wire used
<a href="#">530470410</a>	<a href="#">0510210400</a>	<a href="#">500798000</a>	UL1061, 28AWG

Table 4: Ethernet connector pinout and part numbers

### Cable pinout

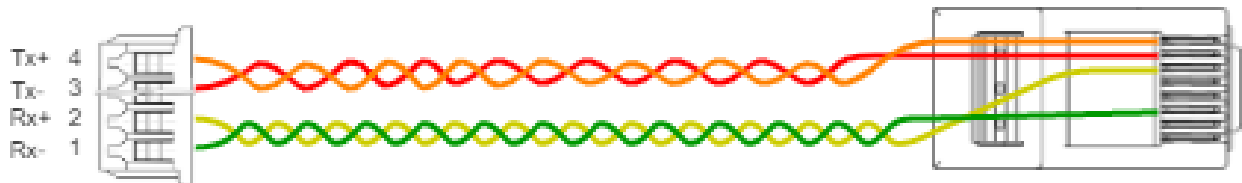
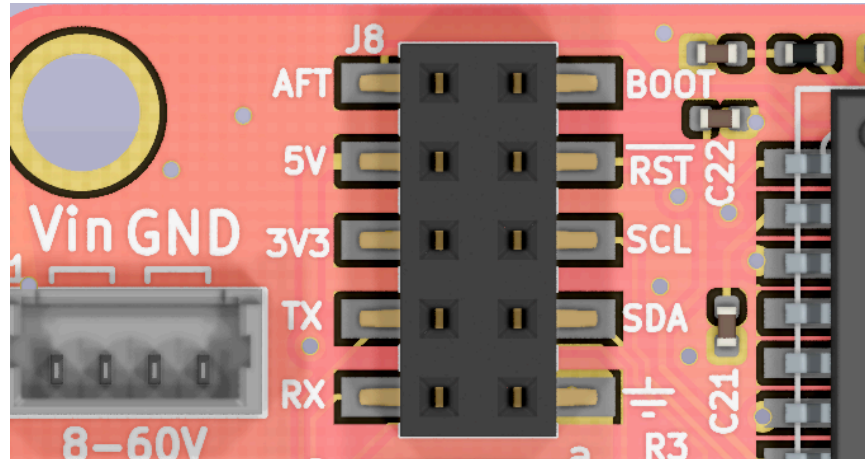

Figure 9: Ethernet cable pinout

### 2.1.4 Extension header

SwitchBlox boards have an extension header for switch management. The extension header provides the following interfaces:

- MDIO/I2C
- Onboard 5V output rail (can be used to supply power to the board).
- Onboard 3V3 rail (can be used to supply power to the board).
- The AFT (Automatic Factory Test) signal, not intended for customer applications.

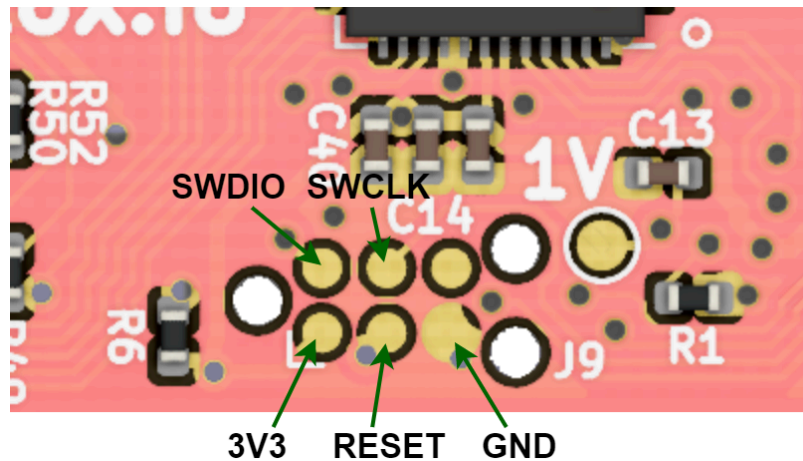

*Figure 10: Extension header pinout*

The part number for the extension header is 0787881014, the mating part for this header is 877581013.

### 2.1.5 SWD Programming Header

A programming header on the back of the board allows SWD access to the STM32 footprint on SwitchBlox. Note that this board does not include the STM32.



*Figure 11: SWD programming header pinout*

This header allows access to the SWD port on a STM32 microcontroller (if soldered onto the board), and requires the use of a 6-pin needle adapter such as the [J-Link 6-pin needle adapter](#) along with an in-circuit programmer such as the [J-Link](#). This board ships without an STM32 soldered.

## 2.2 Other Interfaces

### 2.2.1 LEDs

There are 12 LEDs on SwitchBlox in total. None of the LED signals can be taken off board.

The 5V Power Indicator LED (**Green**) indicates that voltage is present on the 5V line. It should be solid green in normal operation.

The Ethernet IC “ON” Indicator LED (**Green**) indicates that the ethernet IC is powered up and working. It should be solid green in normal operation.

Each Port Activity LED (**Green**) corresponds to a specific port. They indicate activity on each port and will blink when there is traffic on a port. They should be solid off when a port is not connected to any device, and they should blink under normal operation. A solid green LED indicates either constant traffic, or a fault with the port.

## 4 Device Configuration

### 4.1 Unmanaged Switch

To use SwitchBlox in an unmanaged application requires no configuration. Simply connect a voltage to the voltage input and connect downstream devices.

## 5 Device Characteristics

### 5.1 Operating Conditions

#### 5.1.1 Absolute Maximum Ratings

Operating in these ranges will reduce the lifetime of the device.

<b>Voltage Input Maximum</b>	65V
<b>Storage Temperature</b>	-30°C +85°C
<b>Operating Temperature</b>	-10°C to +80°C
<b>5V Output Current</b>	2.3A

#### 5.1.2 Nominal (Test) Ratings

<b>Voltage Input</b>	65V
<b>5V Output Current</b>	0mA

## 6 Datasheet Changelog

Date	Datasheet Version	Author	Notes
30/12/2020	EF_A	Josh Elijah	Initial release
28/01/2021	EF_B	Josh Elijah	PoE R43 resistor note added
15/06/2021	EF_C	Josh Elijah	Added note on J8
11/04/2023	EF_D	Josh Elijah	Added note about removed PoE circuitry
20/09/2023	EF_E	Josh Elijah	Table 1.1.2 General Information updated to be correct values.
25/10/2023	EF_F	Jaclyn Li	Added section 8.
14/11/2023	EF_G	Josh Elijah	Fixed references to STM32 and PoE, made it clear that this revision of the board does not include STM32, and cannot perform PoE. These features have moved to SwitchBlox Industrial.
01/05/2024	EF_H	Jaclyn Li	Updated operating temperature range from "0°C to +70°C" to "-10°C to +80°C"

## 7 Contact

If you have any questions regarding this product, please contact us:

info@botblox.org  
4 Pavilion Court 600 Pavilion Drive,  
Northampton Business Park,  
Northampton,  
England  
NN4 7SL



## 8 Certificate of Conformity

The full text of the Certificate of Conformity of this product is available at the following web address. <https://botblox.io/documentation/>