



# GigaBlox Rugged

Small 4 port 10/100/1000 Mbps  
Ethernet Switch

MPN: BB-GGR-A-1

**Datasheet**

May 2021

Board revision A/B

# Contents

<b>Contents</b>	<b>2</b>
<b>1 General Information</b>	<b>2</b>
1.1 Functionality and Features of GigaBlox Rugged	2
1.2 Safety Information	5
1.3 Block Diagram	5
1.4 Included Equipment	6
1.5 RoHS Certification of Compliance	6
<b>2 Hardware Interfaces</b>	<b>7</b>
2.1 Board Map	7
2.2 Connectors and Pinouts	8
2.3 Other Interfaces	14
<b>3 Software Interfaces</b>	<b>16</b>
3.1 UART	16
<b>4 Device Configuration</b>	<b>17</b>
4.1 Unmanaged Switch	17
<b>5 Device Characteristics</b>	<b>18</b>
5.1 Operating Conditions	18
<b>6 Datasheet Changelog</b>	<b>18</b>
<b>7 Contact</b>	<b>18</b>

# 1 General Information

## 1.1 Functionality and Features of GigaBlox Rugged

GigaBlox Rugged is a very small layer 2 unmanaged and managed ethernet switch that fits four 10/100/1000Mbps copper ethernet ports in an ultra-compact 50mm x 50mm form factor.

GigaBlox Rugged is designed to be a more rugged and more capable upgrade to our GigaBlox product and is designed for space, weight and price-sensitive (SWaP) industrial, mobile and military applications.

### 1.1.1 Features

- 4 x 10/100/1000M (10/100/1000BASE-T) non-blocking ethernet ports
- Input voltage range from 5 to 60V
- Reverse protected voltage input
- Transient protected voltage input
- -40°C to 105°C Operation Range (using a heatsink)
- 50mm x 50mm board size
- Molex Pico-Clasp connectors for power and ports
- Automatic MDI-X crossover
- Unmanaged (out-the-box) functionality
- Embedded NOR Flash to support customised firmware upload for managed switch functions
- Port Activity Indicators

### 1.1.2 General Information

<b>Voltage Input</b>	8V to 60V DC (65V absolute max)
<b>Voltage Output</b>	None
<b>Supported Protocols</b>	10/100/1000BASE-T
<b>Number of ports</b>	4 x 10/100/1000BASE-T
<b>Packet buffer</b>	1.75 MBits
<b>Power Consumption</b>	1W idle, 4W at full data rate
<b>Weight</b>	20 grams
<b>Size</b>	50 mm x 50 mm x 16 mm
<b>Operating Temperature</b>	-40°C to +100°C
<b>Storage Temperature</b>	-55°C to +125°C

*Table 1: General Information*

### 1.1.3 General Operating Instructions

GigaBlox Rugged is designed for use in harsh environments, operating from a nominal supply voltage of 24V, but with the ability to operate from as low as 8V and as high as 60V.

In the simplest case of an unmanaged switch application, GigaBlox Rugged can be operated immediately by following the following steps.

- 1) Apply a voltage between 8V to 60V to the voltage input terminals.
- 2) Connect external devices to the ethernet ports using RJ45 to Pico-Clasp cables.
- 3) GigaBlox Rugged will automatically begin auto negotiation with connected devices and begin receiving and forwarding packets to/from all connected devices.

### 1.2 Safety Information

- This device can operate on voltages near and above 60V. Please read this manual before operating.
- This device is provided “as is”. In-application testing prior to integration is recommended.
- This device is provided as an electronic circuit board, and requires integration into chassis for full ingress protection.
- Do not use this product in wet environments without integrating into a chassis.
- Do not operate this product beyond the rated temperature and voltages.

### 1.3 Block Diagram

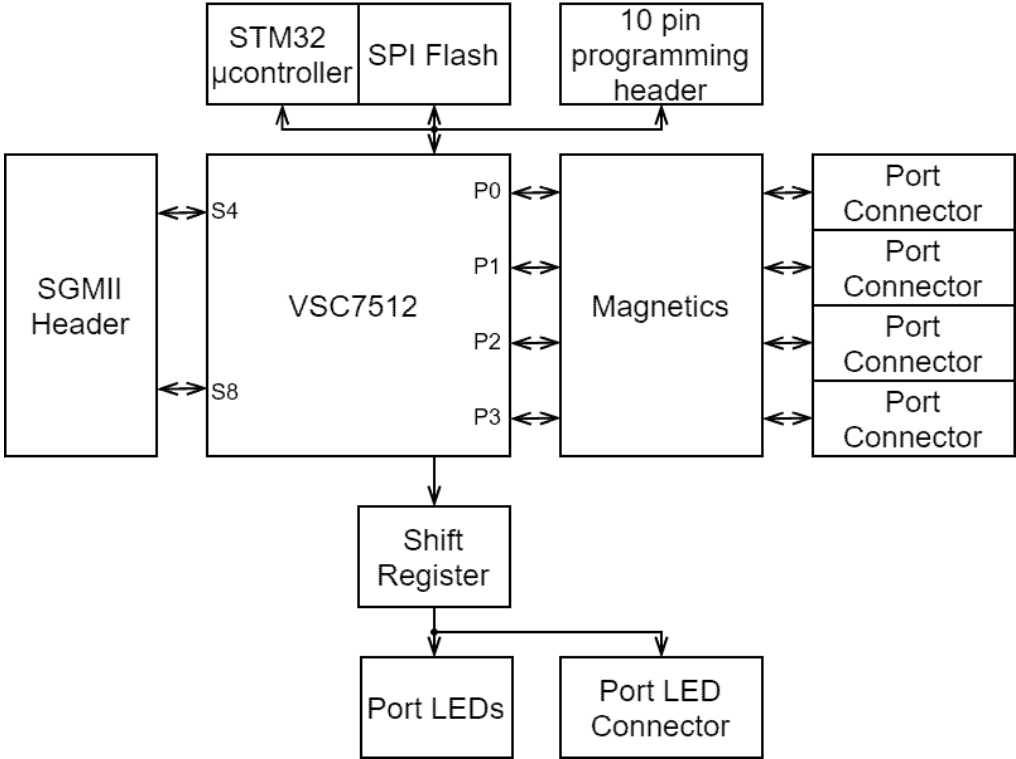

Figure 1: GigaBlox Rugged Block Diagram

## 1.4 Included Equipment

The product includes the following:

1 x GigaBlox Rugged board

4 x Molex Pico-Clasp to RJ45 4-way Shielded Twisted Pair cables (300mm)

1 x Molex Pico-Clasp Power Cable to bare, tinned leads (300mm)

1 x 13mm x 13mm x 10mm heat sink

## 1.5 RoHS Certification of Compliance

GigaBlox Rugged complies with the RoHS (Restriction of Hazardous Substances Directive) Certificate of Compliance.

# 2 Hardware Interfaces

## 2.1 Board Map

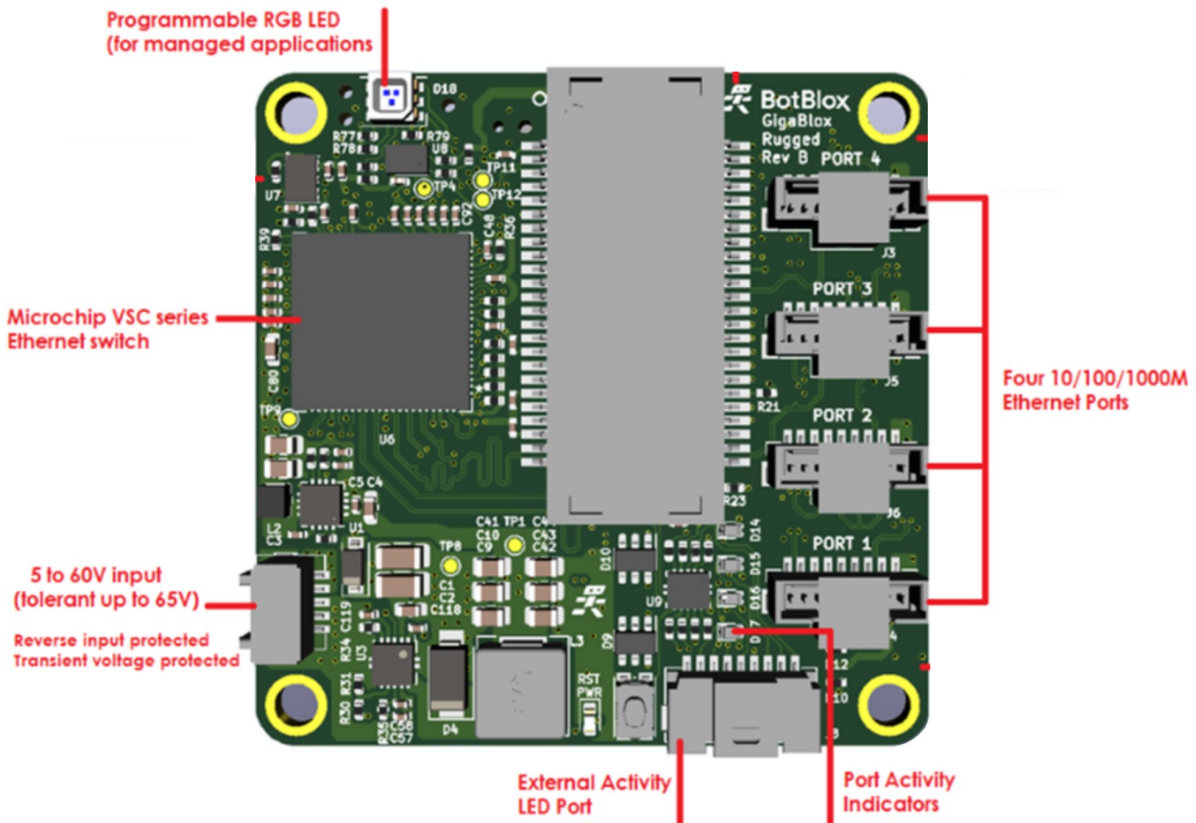

Figure 2: GigaBlox Rugged Board Map (front)

## 2.2 Connectors and Pinouts

### 2.2.1 Voltage Input

The left connector is the voltage input terminal. A five pin connector is used to allow the input voltage to be easily daisy chained between boards (two wires per power rail).

The voltage input has the following features:

- Voltage input can range from 5 to 60V
- Maximum allowable voltage of 65V
- Transient voltage protection above 66.3V
- Reverse polarity protection

The pinout of the voltage input connector is shown in figure 4 below.

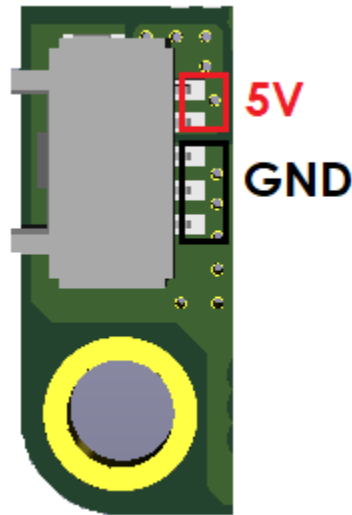

Figure 4: Voltage input header pinout

Connector part numbers

Connector on board	Mating header	Crimp used	Wire used
<a href="#">5019400503</a>	<a href="#">5019390500</a>	<a href="#">500798000</a>	UL1061, 28AWG

Table 2: Voltage input connector pinout and part numbers



## Cable pinout

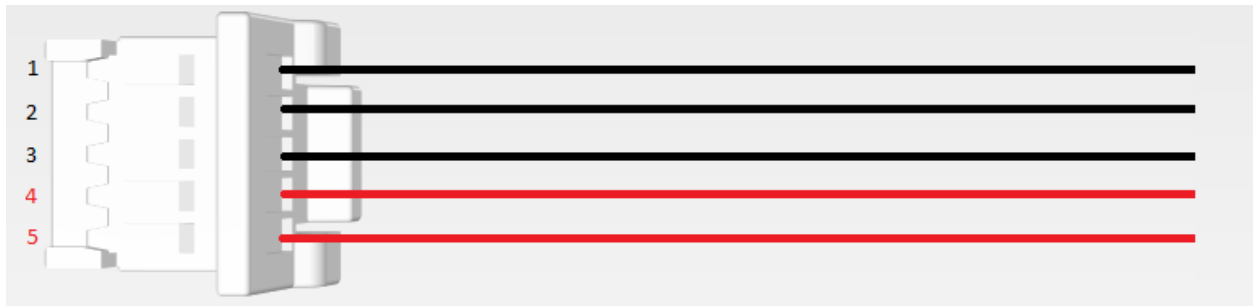

Figure 5: Voltage input cable pinout (red = V+, black = GND)

## 2.2.2 Ethernet Ports

There are four ethernet connectors on GigaBlox Rugged. Each connector has nine pins corresponding to the eight signals required for 1000BASE-T and GND which are A-, A+, B-, B+, D-, D+, C+, C- and GND. The pin mapping of all four connectors is identical.

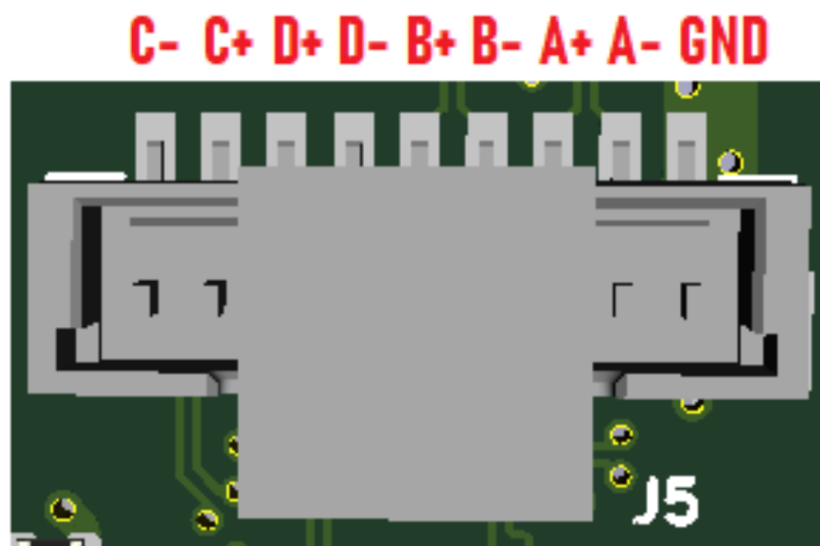

Figure 6: Ethernet port pinout

Connector on board	Mating header	Crimp used	Wire used
<a href="#">5044490907</a>	<a href="#">5013300900</a>	<a href="#">500798000</a>	UL1061, 28AWG

Table 3: Ethernet connector pinout and part numbers

Cable pinout

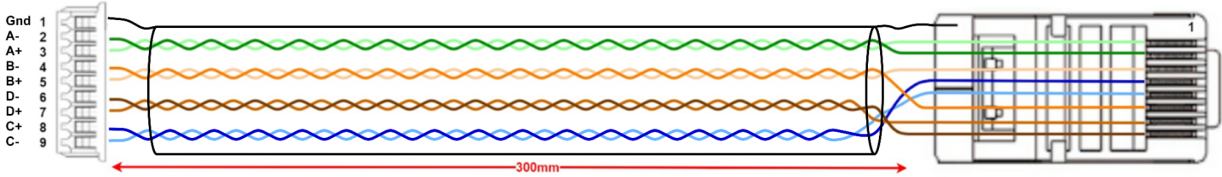

Figure 7: Ethernet cable pinout

### 2.2.3 Extension SGMII header

GigaBlox Rugged exposes SGMII on a stackable header, allowing two GigaBlox Rugged to be stacked together to create a 8 port switch (unmanaged and managed). At present this feature is non-functional but is expected to be enabled on future boards with a firmware update.

The stackable header also allows integration into any other board over SGMII. This can be used for network extension or in-band switch management

To stack two boards, you will need a pin header (MPN:[NRPN072PAEN-RC](#)), 11mm hex standoffs (MPN:[M1258-2545-SS](#)), and M2.5 machines screws (MPN: [29300](#)).

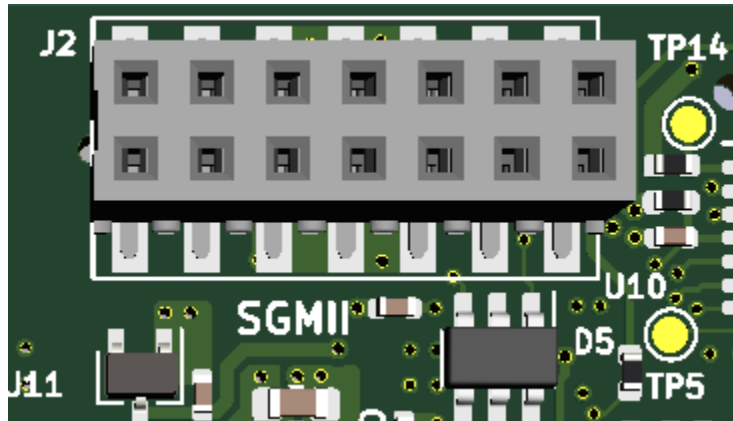

Figure 8: Extension SGMII header pinout

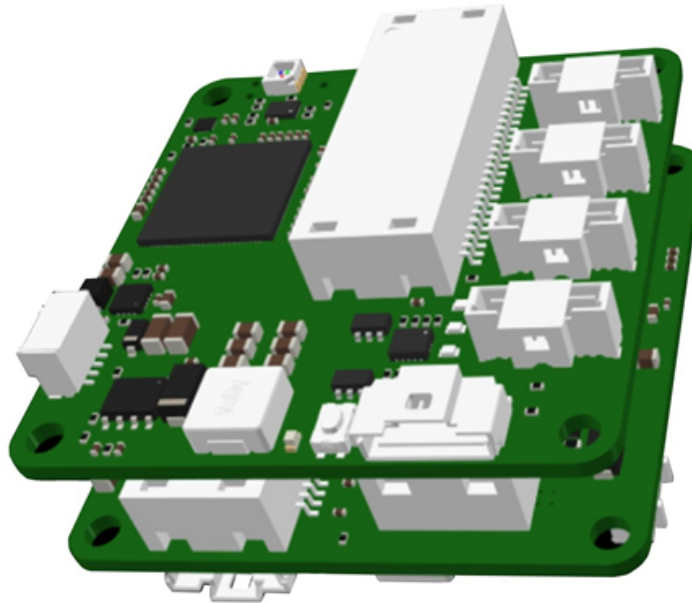

Figure 9: Stackable board

## 2.2.4 Programming Header

The device has two variants: Internal MCU and External MCU

### a. Internal MCU variant

The switch supports four SPI chip-select pins, but only SI\_nCS0 can be used for the internal CPU to boot from Flash. 4 Mbit external Flash is used in this variant, the part number is IS25LQ040B-JULE

A programming header on the back of the board allows the IS25LQ040B on GigaBlox Rugged to be programmed.

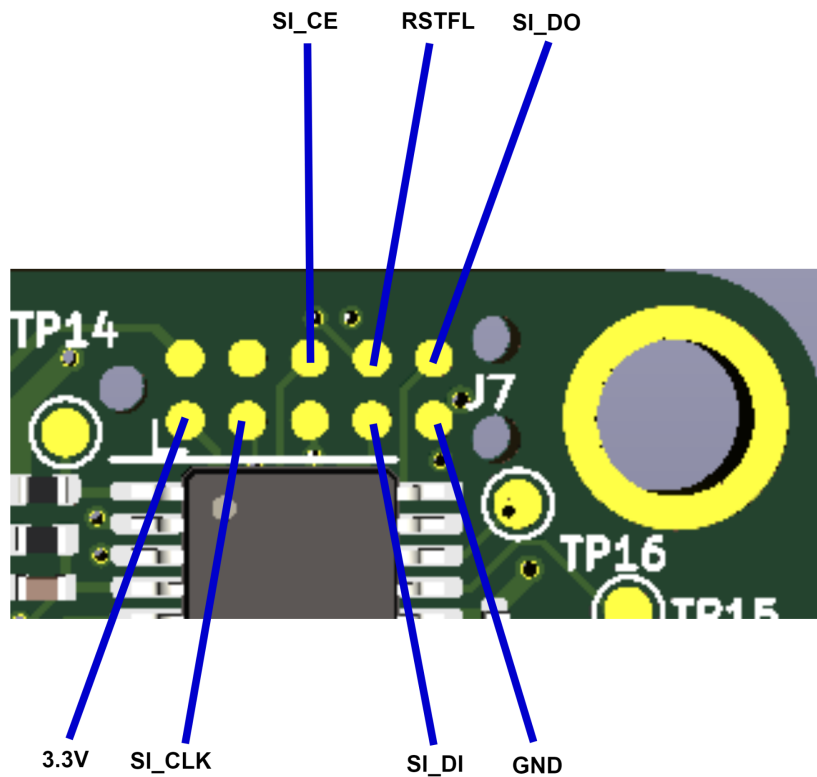

Figure 10: External Flash programming header pinout

This header allows access to the SPI port on the onboard IS25LQ040B Flash, and requires the use of a 10-pin Tag connect [TC2050-IDC-NL](#) cable along with an in-circuit programmer such as the [PRESTO](#) or [FORTE](#) programmer. Below table is connection between GigaBlox Rugged and programmer:

PRESTO / FORTE	GigaBlox Rugged
VDD	3.3V
GND	GND
CLOCK	SI_CLK
MISO	SI_DI
DATA	SI_DO
GND	SPI_CS
VDD	RSFTL

Table 4. GigaBlox Rugged and programmer connection matching

b. External MCU variant

A programming header on the back of the board allows the STM32L011D4P7 on GigaBlox Rugged to be programmed over SWD.

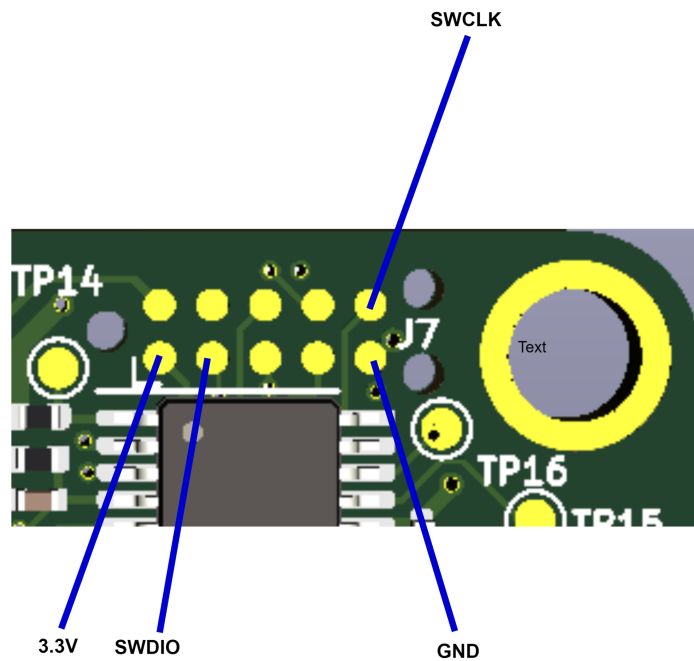

Figure 11: SWD programming header pinout

This header allows access to the SWD port on the onboard STM32 microcontroller, and requires the use of a 6-pin needle adapter such as the [J-Link 6-pin needle adapter](#) along with an in-circuit programmer such as the [J-Link](#).

## 2.2.5 External LED header

An External LED header on the back of the board allows port activity indicator signals can be brought off-board for integration into a chassis

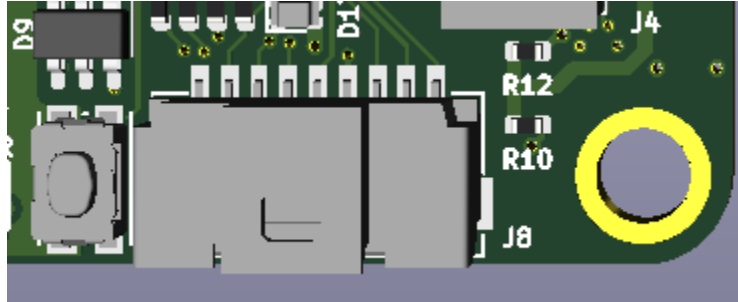

Figure 12: External LED header

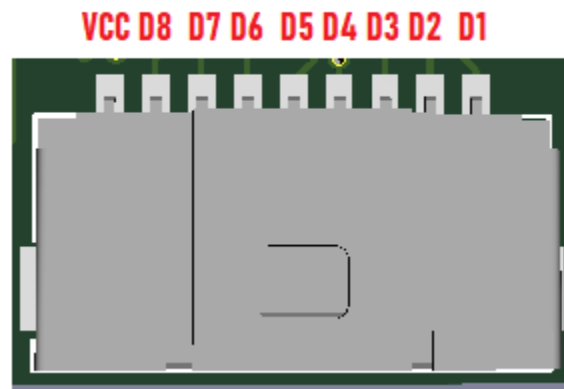

Figure 13: External LED header pinout

The anode of all external LEDs should connect to the 3.3V on the External LED header, and the cathode of the external LED should connect to the corresponding “EX\_LED” connection on the header.

The part used on the board for this header is 2023960907, which mates with 5013300900 (the same connector as used on the ethernet ports).

## 2.3 Other Interfaces

### 2.3.1 LEDs

There are five LEDs on GigaBlox Rugged in total. Four of these LEDs are dual colour LEDs, meaning there are a total of nine LED signals on this board. Eight of the LED signals can be taken off board.

The 3.3V Power Indicator LED (**Green**) indicates that voltage is present on the 3.3V line. It should be solid green in normal operation.

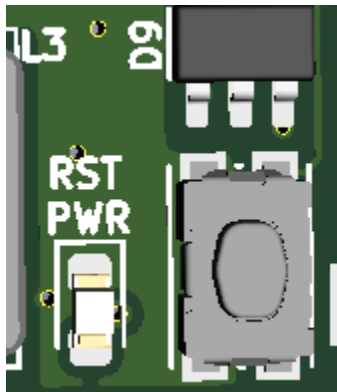

*Figure 14: Power Indicator LED*

Each Port Activity LED is a **Red/Green** dual color LED and each corresponds to a specific port. They indicate activity on each port and will blink when there is traffic on a port. They should be solid off when a port is not connected to any device, and they should blink under normal operation (orange blinking indicates a 1000 Mbps connection, red blinking indicates a 100Mbps connection). A solid LED indicates either constant traffic, or a fault with the port.

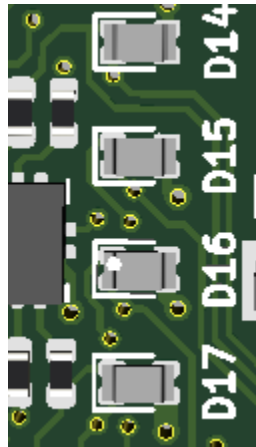
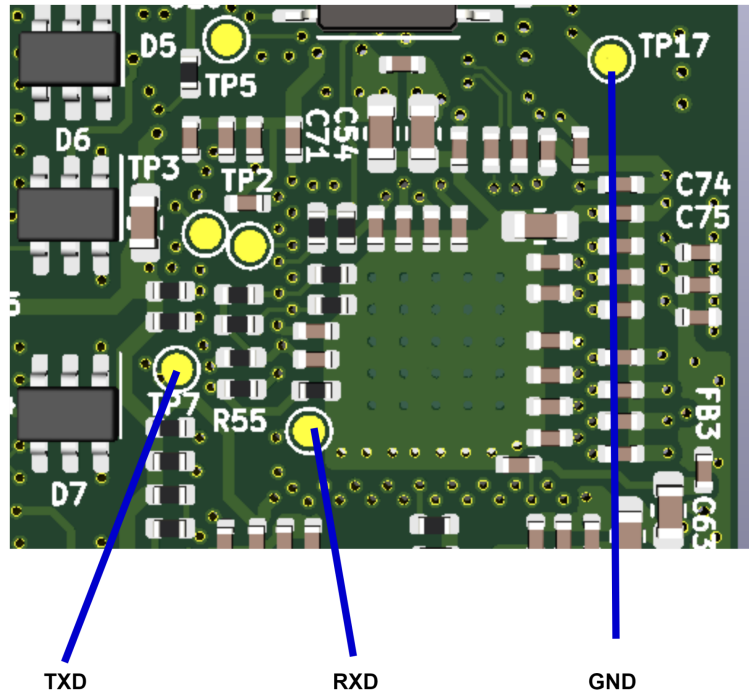

*Figure 15: Port Activity Dual Red/Yellow-Green LED*

## 3 Software Interfaces

### 3.1 UART

The VSC7511 supports two UART interfaces. The first UART is overlaid on GPIO\_6 and GPIO\_7, and is used by the software as the command line interface for debugging.



*Figure 16: Switch Controller UART position*



## 4 Device Configuration

### 4.1 Unmanaged Switch

To use GigaBlox in an unmanaged application requires no configuration. Simply connect a voltage to the voltage input and connect downstream devices.

## 5 Device Characteristics

### 5.1 Operating Conditions

#### 5.1.1 Absolute Maximum Ratings

Operating in these ranges will reduce the lifetime of the device.

<b>Voltage Input Maximum</b>	65V
<b>Storage Temperature</b>	-40°C +125°C
<b>Operating Temperature</b>	-40°C +100°C

## 6 Datasheet Changelog

<b>Date</b>	<b>Datasheet Version</b>	<b>Author</b>	<b>Notes</b>
29/05/2021	EF_A	Josh Elijah	Initial release

## 7 Contact

If you have any questions regarding this product, please contact us:

josh@kapek  
4 Pavilion Court 600 Pavilion Drive,  
Northampton Business Park,  
Northampton,  
England  
NN4 7SL